

GLOBALLY RAISING THE STANDARDS OF FOOD THROUGH THE ART OF SLICING

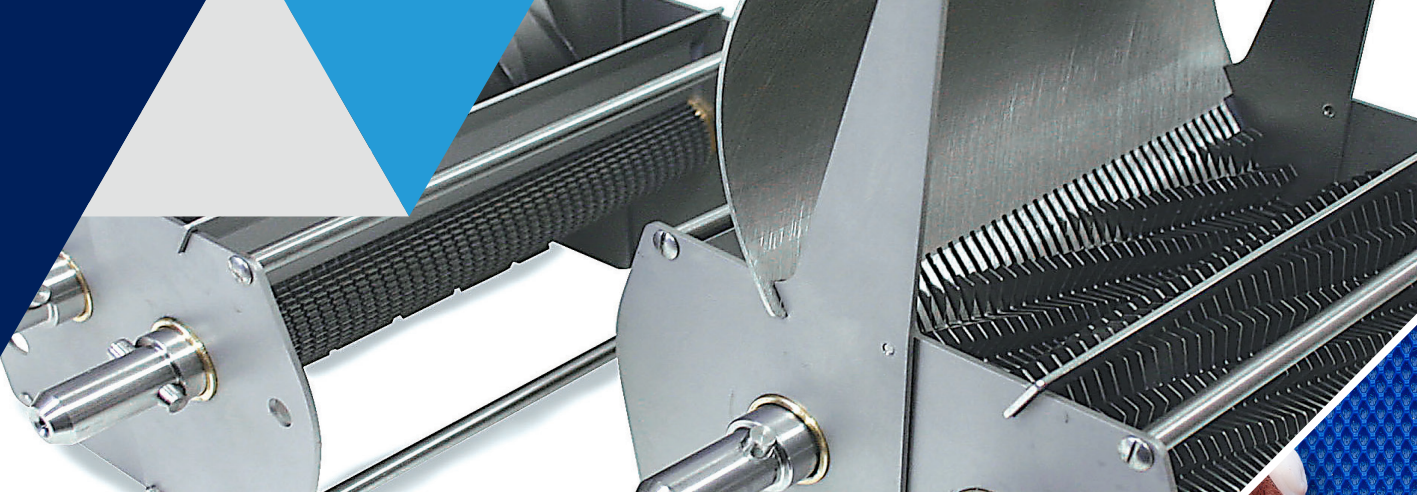

ST200

Table Top strip
cutter/tenderizer



CUBETTATRICE/INTENERITRICE



ST200

Compatta, robusta, essenziale, la soluzione ideale per chi desidera una piccola macchina affidabile, versatile e facile da igienizzare.

Cubettatrice e inteneritrice per prodotto fresco senz'osso.

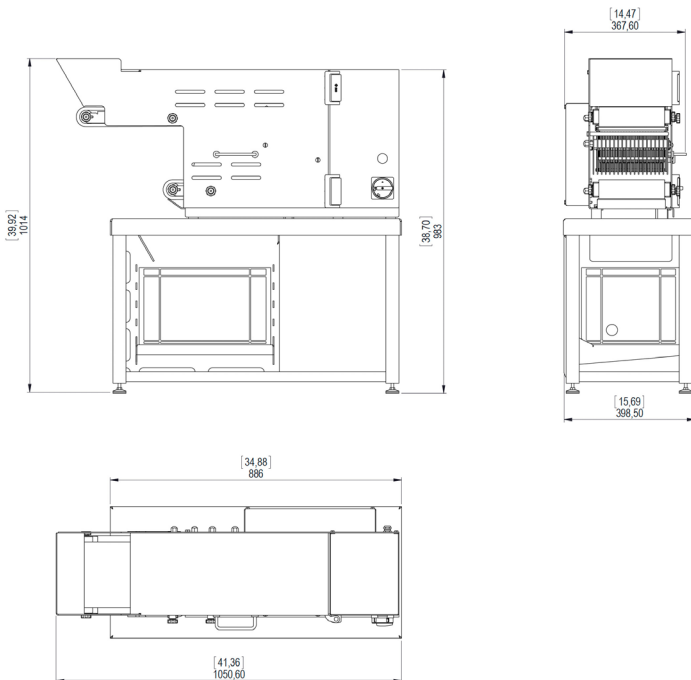

Dati Tecnici

	ST200
Height	494 mm / 19.54"
Width	1038 mm / 40.85"
Depth	371 mm / 14,6"
Weight	80 Kg - 176.37 lb
Motor Power	0.4 Kw
Maximum cutting width	200 mm / 7.87"
Minimum strip thickness (5mm pitch)	5 mm - 0.2"
Working speed	0.245m/sec
Overall dimension with basement (W x D x H) *OPTIONAL	1038x553,5x995 40.85x21.79x39.17



1. Perfetto per ristoranti, catering o macellerie

ST200 può essere convertita in pochi secondi da una macchina per la produzione di strisce o cubetti di prodotto fresco senz'osso a macchina inteneritrice, senza che sia richiesto alcun utensile.



2. Facile accesso per la manutenzione e sanificazione

Facile igienizzazione senza attrezzi grazie al minimo ingombro sul tavolo, pieno accesso ai set di taglio o intenerimento sia per la pulizia che per la sostituzione.



3. Buona capacità di taglio e intenerimento della carne

Grande capacità di taglio e intenerimento senza necessità di raffreddare o preparare il prodotto prima della lavorazione.



4. Facile da usare

È User-friendly, non è necessario un tecnico specializzato Grasselli per il primo utilizzo.



5. Posiziona la macchina ovunque tu voglia

Aggiungendo l'opzionale basamento in acciaio inox dedicato, ST200 può essere trasformata in una macchina indipendente, facile da spostare nell'area di lavoro, senza bisogno di collegamento pneumatico.

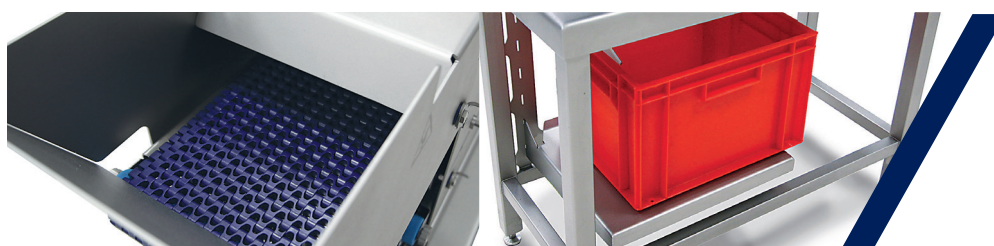

Visit our website

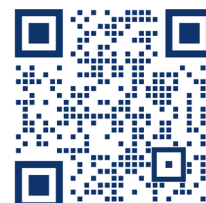

TABLE TOP STRIP CUTTER/TENDERIZER



ST200

Compact, steady, essential, the ideal solution for anyone who wishes for a reliable, versatile, easy to sanitize small machine.

Strip cutter for fresh boneless products.

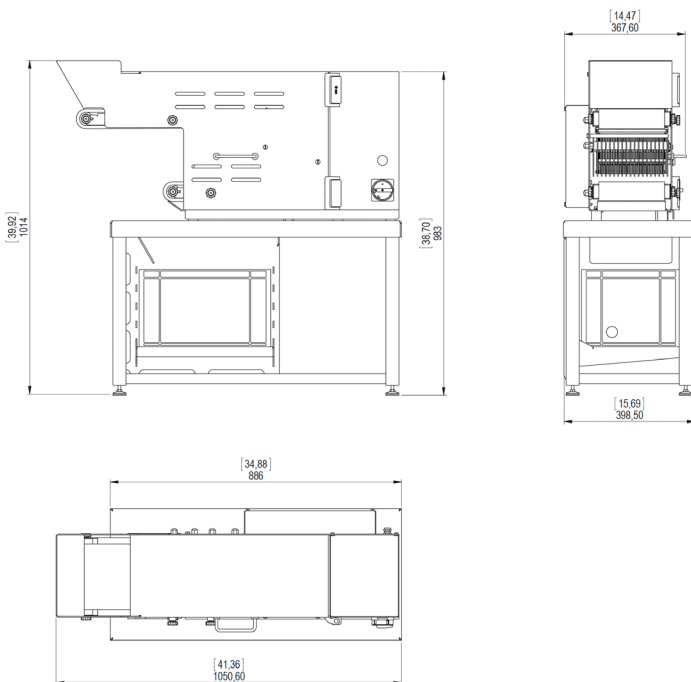

Technical Data

	ST200
Height	494 mm / 19.54"
Width	1038 mm / 40.85"
Depth	371 mm / 14,6"
Weight	80 Kg - 176.37 lb
Motor Power	0.4 Kw
Maximum cutting width	200 mm / 7.87"
Minimum strip thickness (5mm pitch)	5 mm - 0.2"
Working speed	0.245m/sec
Overall dimension with basement (W x D x H) *OPTIONAL	1038x553,5x995 40.85x21.79x39.17

ST200

TABLE TOP STRIP CUTTER/TENDERIZER



1. Perfect for restaurants, catering companies or butchers

ST200 can be converted in a few seconds from a machine for the production of strips and cubes of fresh boneless products into a tenderizer without the need of any tool.



2. Easy access for maintenance and sanitation

Easy sanitation thanks to the minimum footprint on table and tool-free, full access to the cutting or tenderizing sets for either cleaning or replacement.



3. Great capacity for cutting and tenderizing meat

High capacity for both slicing and tenderizing without the need to trim or chill the product before processing.



4. Intuitive to use

User-friendly, no need of any skilled Grasselli technician for the start up.



5. Put the machine wherever you want

By adding the dedicated optional stainless steel basement, ST 200 can be transformed into an independent machine, easier to move within the processing area, with no pneumatic connection needed.

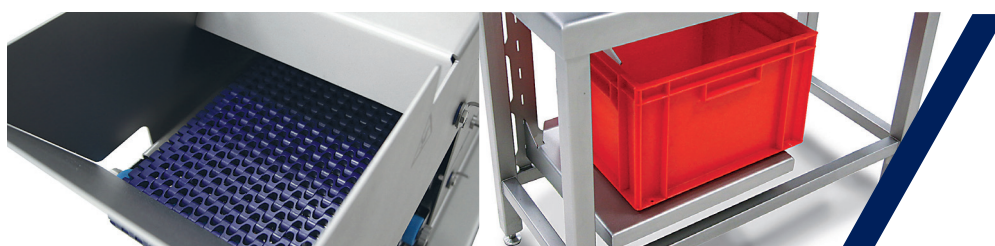

Visit our website

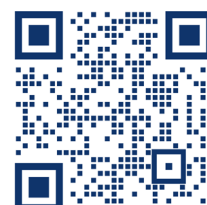

МАШИНА ДЛЯ НАРЕЗКИ НА КУБИКИ И ТЕНДЕРИЗАЦИИ МЯСА



ST200

Компактная, прочная и простая: идеальное решение для тех, кому нужна небольшая машина, надежная, универсальная и легко поддающаяся дезинфекции.

Машина для нарезки на кубики и тендеризации свежего бескостного мяса.

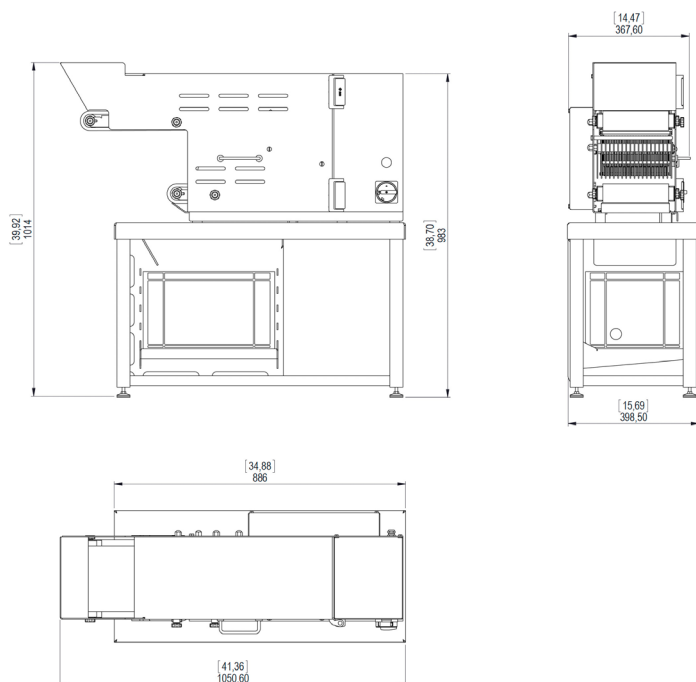

Технические данные

	ST200
Height	494 mm / 19.54"
Width	1038 mm / 40.85"
Depth	371 mm / 14,6"
Weight	80 Kg - 176.37 lb
Motor Power	0.4 Kw
Maximum cutting width	200 mm / 7.87"
Minimum strip thickness (5mm pitch)	5 mm - 0.2"
Working speed	0.245m/sec
Overall dimension with basement (W x D x H) *OPTIONAL	1038x553,5x995 40.85x21.79x39.17



1. Идеально подходит для ресторанов, предприятий общественного питания и мясных магазинов

ST200 можно за считанные секунды превратить из машины для производства ломтиков или кубиков бескостного свежего мяса в машину для, причем для этого не требуется никаких инструментов.



2. Легкий доступ для технического обслуживания и дезинфекции

Простая дезинфекция без использования инструментов благодаря минимальным габаритам стола, полный доступ к комплектующим резки или тендеризации как для очистки, так и для замены.



3. Высокая режущая и тендеризирующая способность

Высокая режущая и тендеризирующая способность без необходимости охлаждения или подготовки продукта перед обработкой.



4. Простота в использовании

Машина является дружелюбной к пользователю, для ее первого применения не требуется специалист по оборудованию Grasselli.



5. Расположите машину в любом удобном для вас месте

В При установке опционального специального основания из нержавеющей стали ST200 может быть преобразована в отдельно стоящую машину, которую легко перемещать по рабочей зоне, без необходимости подключения к магистрали сжатого воздуха.

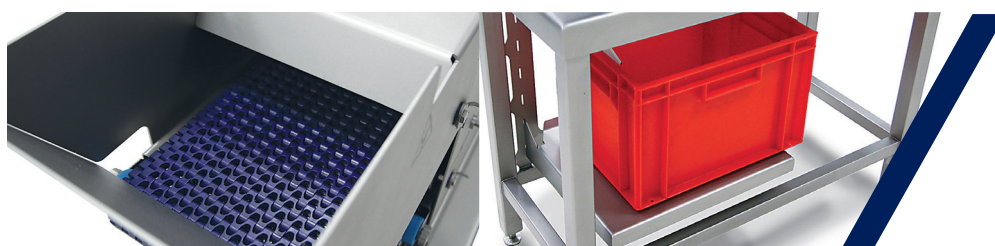

Visit our website

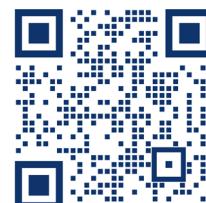

CUBETeadora/ABLANDADORA



ST200

Compacta, robusta, esencial, la solución ideal para quienes desean una máquina pequeña, fiable, versátil y fácil de desinfectar.

Máquina para cortar en cubos y ablandar el producto fresco deshuesado.

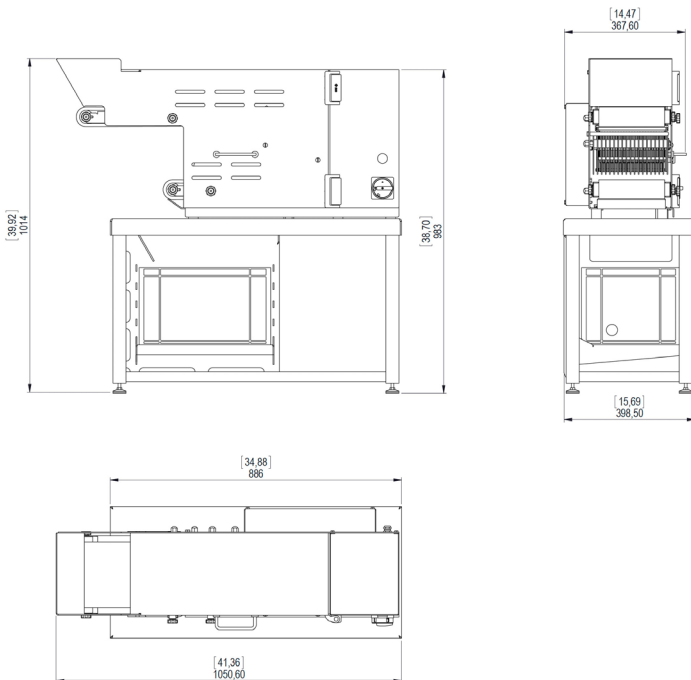

Datos Técnicos

	ST200
Height	494 mm / 19.54"
Width	1038 mm / 40.85"
Depth	371 mm / 14,6"
Weight	80 Kg - 176.37 lb
Motor Power	0.4 Kw
Maximum cutting width	200 mm / 7.87"
Minimum strip thickness (5mm pitch)	5 mm - 0.2"
Working speed	0.245m/sec
Overall dimension with basement (W x D x H) *OPTIONAL	1038x553,5x995 40.85x21.79x39.17



1. Perfecta para restaurantes, empresas de catering o carnicerías

La ST200 puede pasar en segundos de una máquina para cortar en tiras o cubos el producto fresco deshuesado a una máquina ablandadora, sin necesidad de herramientas.



2. Fácil acceso para el mantenimiento y la desinfección

Fácil limpieza sin herramientas gracias al mínimo espacio de la mesa, acceso total a los kits de corte o de piezas para su limpieza y sustitución.



3. Buena capacidad de corte y ablandamiento de la carne

Gran capacidad de corte y ablandamiento sin necesidad de enfriar o preparar el producto antes de procesarlo.



4. Fácil de usar

Es fácil de usar, no se necesita un técnico especializado de Grasselli para su puesta en funcionamiento.



5. Coloque la máquina donde quiera

Añadiendo la base opcional de acero inoxidable, la ST200 puede transformarse en una máquina independiente, fácil de mover por el área de trabajo, sin necesidad de conexión neumática.

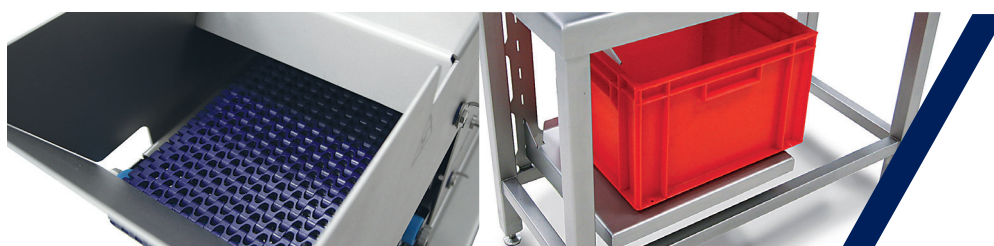

Visit our website



WÜRFELSCHNEIDER/WEICHMACHER



ST200

Kompakt, robust, unverzichtbar - die ideale Lösung für alle, die eine kleine, zuverlässige, vielseitige und leicht zu reinigende Maschine suchen.

Maschine zum Würfelschneiden und Weichmachen von frischem Produkt ohne Knochen.

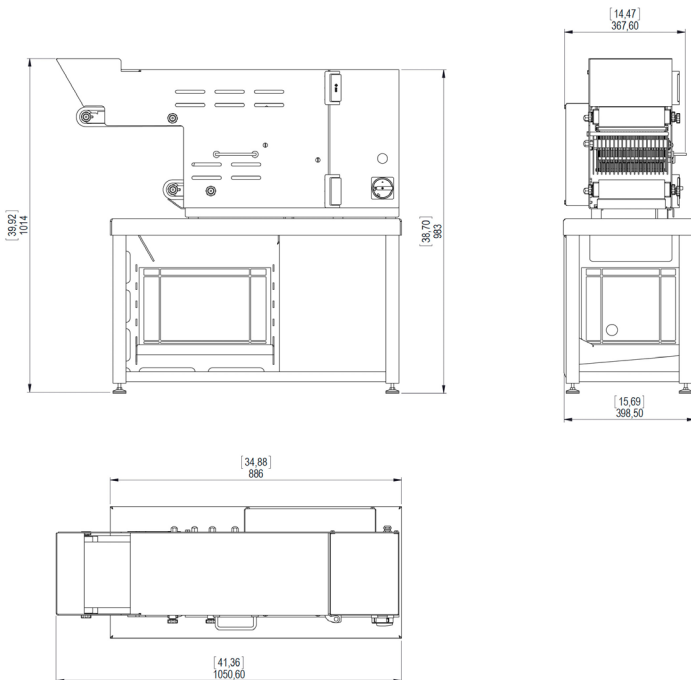

Technische Daten

	ST200
Height	494 mm / 19.54"
Width	1038 mm / 40.85"
Depth	371 mm / 14,6"
Weight	80 Kg - 176.37 lb
Motor Power	0.4 Kw
Maximum cutting width	200 mm / 7.87"
Minimum strip thickness (5mm pitch)	5 mm - 0.2"
Working speed	0.245m/sec
Overall dimension with basement (W x D x H) *OPTIONAL	1038x553,5x995 40.85x21.79x39.17



1. Ideal für Restaurants, Caterer oder Metzgereien

Der ST200 lässt sich in Sekundenschnelle von einer Maschine zur Herstellung von Streifen oder Würfeln aus knochenlosem Frischfleisch in eine Weichmacher-Maschine umwandeln, ohne dass Werkzeuge erforderlich sind.



2. Einfacher Zugang für Wartung und Reinigung

Einfache, werkzeuglose Reinigung durch minimalen Platzbedarf auf dem Tisch, voller Zugang zu den Schneid- oder Weichmachersätzen für Reinigung und Austausch



3. Gutes Schneiden und Weichmachen von Fleisch

Hohe Schneide- und Weichmacherleistung ohne die Notwendigkeit, das Produkt vor der Verarbeitung zu kühlen oder vorzubereiten.



4. Einfach zu bedienen

Es ist benutzerfreundlich, für die erste Anwendung ist kein spezialisierter Grasselli-Techniker erforderlich.



5. Stellen Sie die Maschine auf, wo immer Sie wollen!

Mit dem optionalen Sockel aus rostfreiem Stahl kann die ST200 in eine freistehende Maschine verwandelt werden, die sich leicht im Arbeitsbereich bewegen lässt, ohne dass ein pneumatischer Anschluss erforderlich ist.

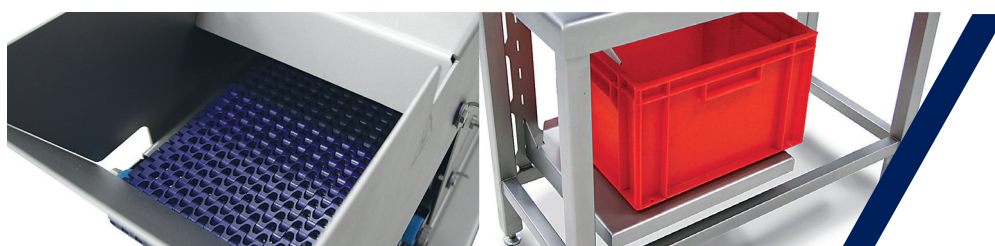

Visit our website

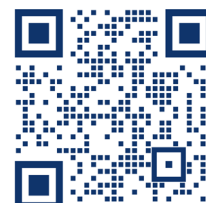

CUBEUSE/MASSEUR



ST200

Compacte, robuste, essentielle, c'est la solution idéale pour ceux qui souhaitent avoir une petite machine fiable, polyvalente et facile à assainir.

Cubeuse et masseur pour produits frais désossés.

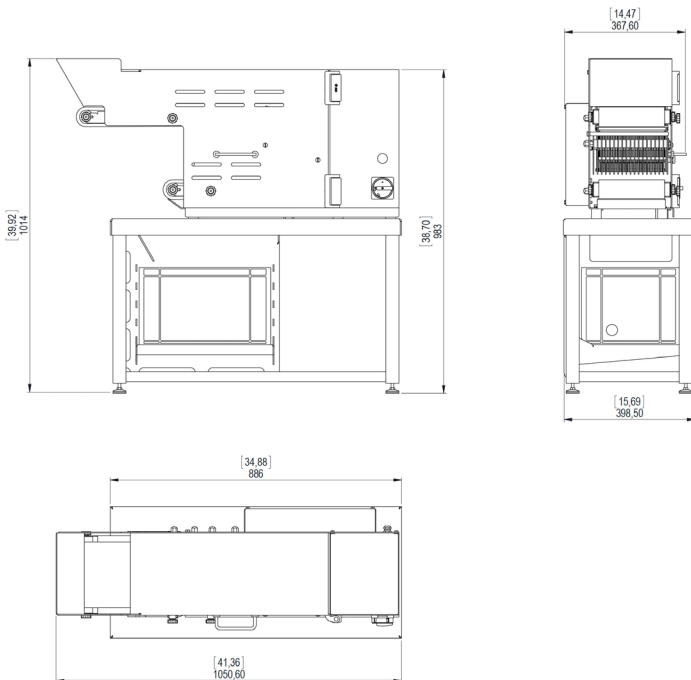

Données techniques

	ST200
Height	494 mm / 19.54"
Width	1038 mm / 40.85"
Depth	371 mm / 14,6"
Weight	80 Kg - 176.37 lb
Motor Power	0.4 Kw
Maximum cutting width	200 mm / 7.87"
Minimum strip thickness (5mm pitch)	5 mm - 0.2"
Working speed	0.245m/sec
Overall dimension with basement (W x D x H) *OPTIONAL	1038x553,5x995 40.85x21.79x39.17



1. Parfaite pour les restaurants, les traiteurs ou les bouchers

La ST200 peut être convertie en quelques secondes d'une machine destinée à produire des bandes ou des cubes de produits frais désossés en une machine à masser la viande, sans aucun outil



2. Accès facile pour l'entretien et la désinfection

Nettoyage facile et sans outil grâce aux dimensions d'encombrement réduites sur la table, accès complet aux ensembles de coupe ou massage pour le nettoyage et le remplacement.



3. Bonne capacité de découpe et massage de la viande

Grande capacité de coupe et de massage sans qu'il soit nécessaire de refroidir ou de préparer le produit avant le traitement.



4. Facile à utiliser

Elle est conviviale, aucun technicien spécialisé de Grasselli n'est nécessaire pour la première utilisation.



5. Positionnez la machine où vous voulez

En ajoutant la base en acier inoxydable dédiée en option, la ST200 peut être transformée en une machine autonome, facile à déplacer dans la zone de travail, sans besoin de connexion pneumatique.

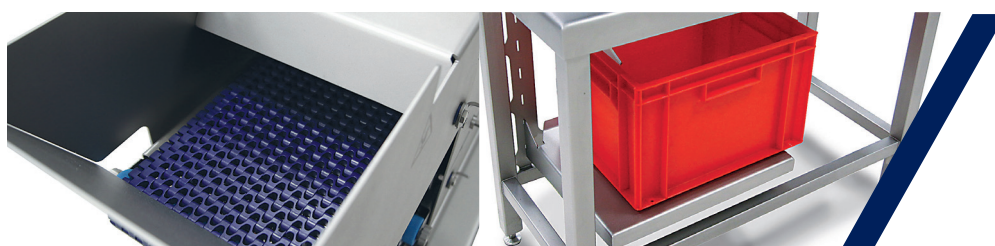

Visit our website

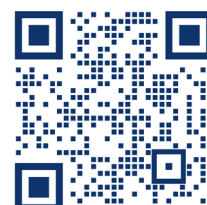

CORTADOR DE CARNE EM CUBOS/AMACIADOR DE CARNE



ST200

Compacto, robusto, essencial, a solução ideal para os que querem uma máquina pequena, fiável, versátil e fácil de higienizar.

Cortador de carne em cubos e amaciador de carne para produtos frescos sem osso.

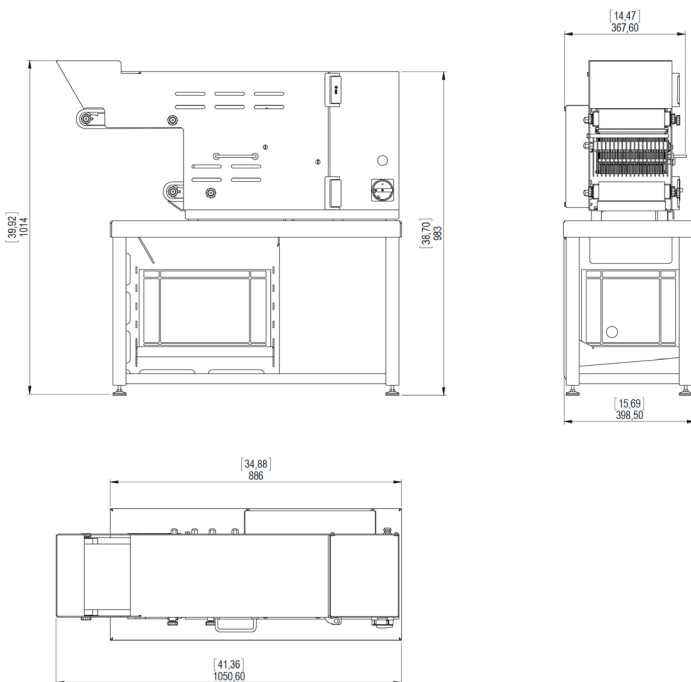

Dados Técnicos

	ST200
Height	494 mm / 19.54"
Width	1038 mm / 40.85"
Depth	371 mm / 14,6"
Weight	80 Kg - 176.37 lb
Motor Power	0.4 Kw
Maximum cutting width	200 mm / 7.87"
Minimum strip thickness (5mm pitch)	5 mm - 0.2"
Working speed	0.245m/sec
Overall dimension with basement (W x D x H) *OPTIONAL	1038x553,5x995 40.85x21.79x39.17



1. Perfeito para restaurantes, fornecedores de refeições ou açougueiros

O ST200 pode ser convertido em segundos de uma máquina para produzir tiras ou cubos de produto fresco sem osso para uma máquina de amaciar, sem necessidade de ferramentas.



2. Fácil acesso para manutenção e higienização

Higienização fácil sem ferramentas devido ao espaço mínimo que ocupa na mesa, acesso total aos conjuntos de corte ou de amaciamento tanto para limpeza como para substituição.



3. Boa capacidade de corte e amaciamento da carne

Alta capacidade de corte e amaciamento sem necessidade de arrefecer ou preparar o produto antes do processamento.



4. Fácil de usar

É de fácil utilização, não é necessário nenhum técnico especializado da Grasselli para a primeira utilização.



5. Posicione a máquina onde quiser

Ao adicionar a base opcional dedicada de aço inoxidável, o ST200 pode ser transformado numa máquina autônoma, fácil de deslocar na área de trabalho, sem necessidade de ligação pneumática.

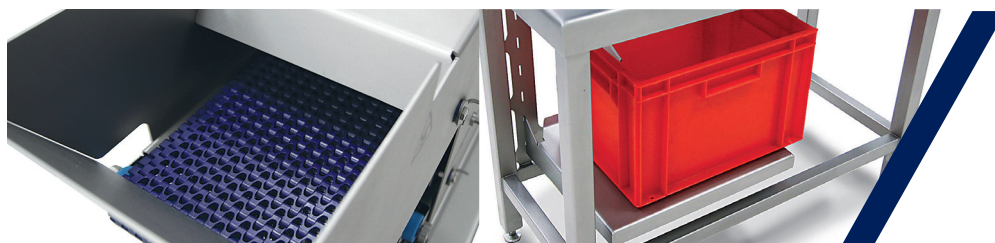

Visit our website

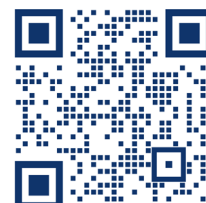

切丁机/嫩肉机



ST200

这是一款紧凑耐用、质量可靠、功多样能、易于消毒的小型机器,是客户日常必备的理想选择

无骨鲜肉切丁机和嫩肉机。

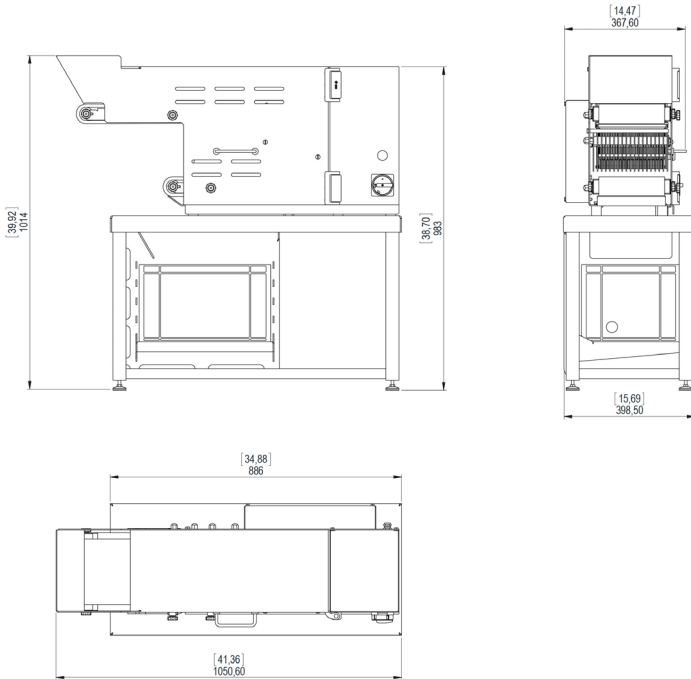

技术参数

	ST200
Height	494 mm / 19.54"
Width	1038 mm / 40.85"
Depth	370 mm / 14.6"
Weight	80 Kg - 176.37 lb
Motor Power	0.4 Kw
Maximum cutting width	200 mm / 7.87"
Minimum strip thickness (5mm pitch)	5 mm - 0.2"
Working speed	0.245m/sec
Overall dimension with basement (W x D x H) *OPTIONAL	1038x553,5x995 40.85x21.79x39.17

ST200

切丁机/嫩肉机



1. 适用于饭馆、配餐店或肉店

ST200 能够在不使用任何工具的情况下仅花几秒钟从用于生产无骨鲜肉条或块的机器转换为嫩肉机。



2. 易于维护和消毒

由于外形尺寸非常小, 易于实现卫生条件, 并且无需工具就可以接触切割或嫩化整套刀具进行清洁和更换。



3. 良好的切割和嫩化肉的能力

强大的切割和嫩化能力, 无需在加工前冷却或准备产品。



4. 便于使用

用户友好型, 第一次使用不需要 Grasselli 专业技术人员。



5. 机器随心所欲

添加可选专用不锈钢底座, ST200 能够变成一台独立的机器, 便于移动至工作区, 无需气动连接。

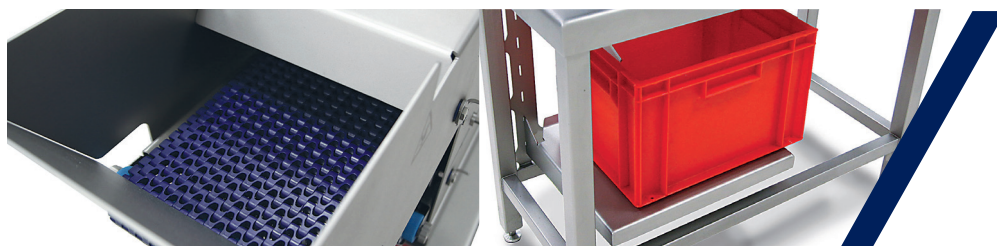

Visit our website



