

GLOBALLY RAISING THE STANDARDS OF FOOD THROUGH THE ART OF SLICING

T300F

Compact membrane skinner
for fresh fish

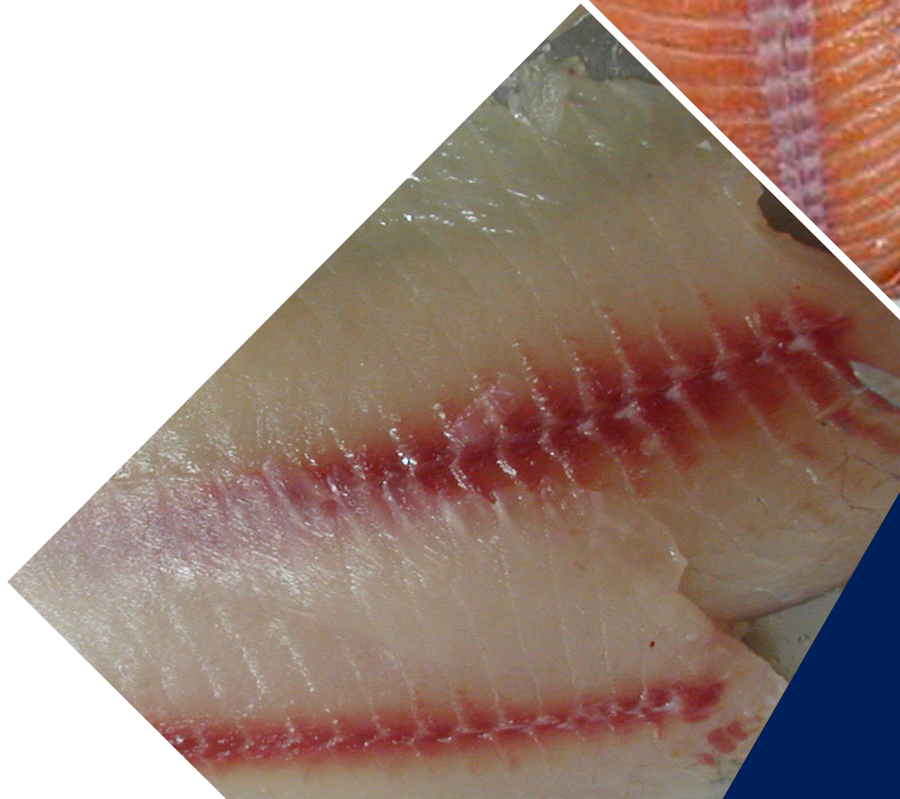



T 300F

Spellatrice compatta per pesce fresco.

Garantisce risultati eccellenti nonostante le dimensioni ridotte.

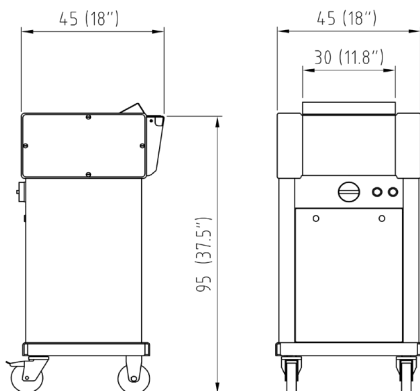

Dati Tecnici

	T300F
Height	980 mm / 38.58"
Width	450 mm / 17.72"
Depth	450 mm / 17.72"
Weight	104 Kg - 229.28 lb
Motor Power	0.37 Kw
Noise Level	71 db
Maximum working width	300 mm / 11.81"
Work Speed	24m/min - 80.6 ft/min
Operator control circuit	24V
Water consumption*	4lt/min

*optional

T300F

SPELLATRICE COMPATTA PER PESCE FRESCO



1. Piano di lavoro ergonomico

Area di lavoro ergonomica e piano di lavoro libero da impedimenti per una migliore manipolazione del prodotto durante la lavorazione.



2. Posizionala dove vuoi

Con le sue dimensioni compatte, T300 F richiede il minimo spazio ed è ideale per negozi e grandi cucine.



3. Facile igienizzazione

Estremamente facile da pulire, senza la necessità di preparare utensili per la sanificazione.



4. Lavorazione efficiente e pulita

T300F è dotata di un contenitore per la raccolta della pelle per evitare che cada, consentendo il deflusso dell'acqua utilizzata durante la lavorazione.



5. Durevole nel tempo

Rullo dentato temperato per aumentare la vita utile dei componenti e ridurre le manutenzioni.

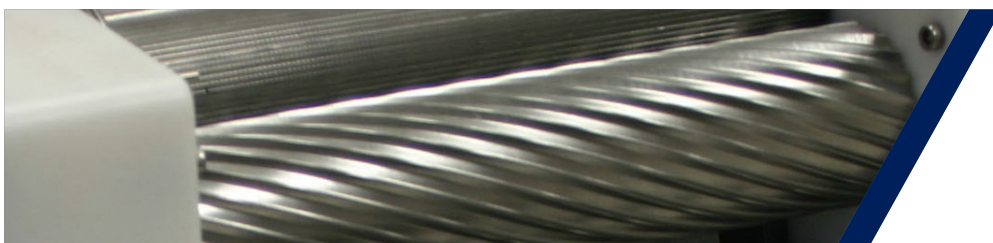

Visit our website

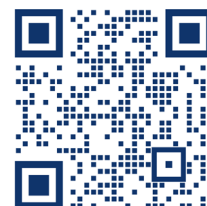

COMPACT MEMBRANE SKINNER FOR FRESH FISH



T 300F

Compact membrane skinner for fresh fish.

Guarantees excellent results in spite of the reduced size.

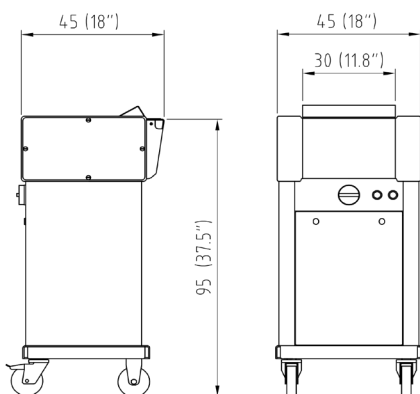

Technical Data

	T300F
Height	980 mm / 38.58"
Width	450 mm / 17.72"
Depth	450 mm / 17.72"
Weight	104 Kg - 229.28 lb
Motor Power	0.37 Kw
Noise Level	71 db
Maximum working width	300 mm / 11.81"
Work Speed	24m/min - 80.6 ft/min
Operator control circuit	24V
Water consumption*	4lt/min

*optional

T300F

COMPACT MEMBRANE SKINNER FOR FRESH FISH



1. Ergonomic working table

Ergonomic working area and free work table for better handling of the product during processing.



2. Place it wherever you want

With its compact dimensions, T300 F requires minimum space and is ideal for stores and large kitchens.



3. Easy sanitation

Extremely easy to clean, with no tools needed to prepare for the sanitation process.



4. Efficient, neat processing

T300F is fitted with a container for collecting the skins to prevent them from falling, allowing the water used during processing to be drained away .



6. Durable

Tempered toothroller to improve durability and ensure longevity.

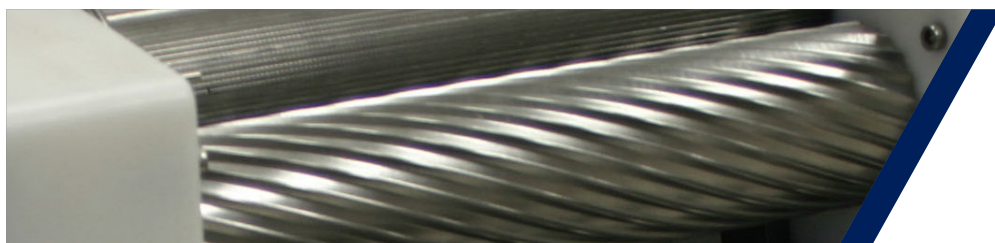

Visit our website

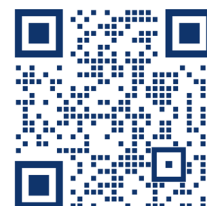



T 300F

Компактная машина для чистки свежей рыбы.
Обеспечивает превосходные результаты, несмотря на свои небольшие размеры.

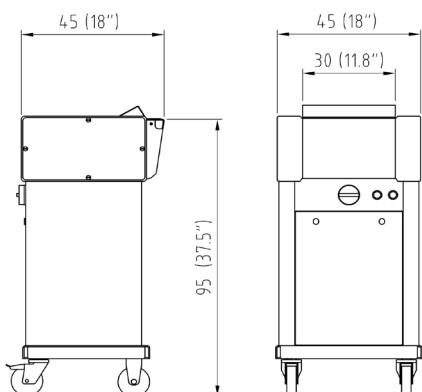

Технические данные

	T300F
Height	980 mm / 38.58"
Width	450 mm / 17.72"
Depth	450 mm / 17.72"
Weight	104 Kg - 229.28 lb
Motor Power	0.37 Kw
Noise Level	71 db
Maximum working width	300 mm / 11.81"
Work Speed	24m/min - 80.6 ft/min
Operator control circuit	24V
Water consumption*	4lt/min

*optional



1. Эргономичная рабочая поверхность

Эргономичная рабочая зона и свободная от препятствий рабочая поверхность обеспечивает улучшенное обращение с продуктом во время обработки.



2. Разместите ее в любом удобном для вас месте

Благодаря своим компактным размерам T300 F занимает минимум места и идеально подходит для магазинов и больших кухонь.



3. Легкая дезинфекция

Машина очень легко чистится, без необходимости подготовки дезинфицирующих средств.



4. Эффективная и чистая обработка

Машина T300F оснащена контейнером для сбора кожи для предотвращения ее падения, что позволяет стекать воде, используемой в ходе обработки.



5. Продолжительный срок службы

Закаленный зубчатый вал, служащий для увеличения срока службы компонентов и сокращения технического обслуживания.

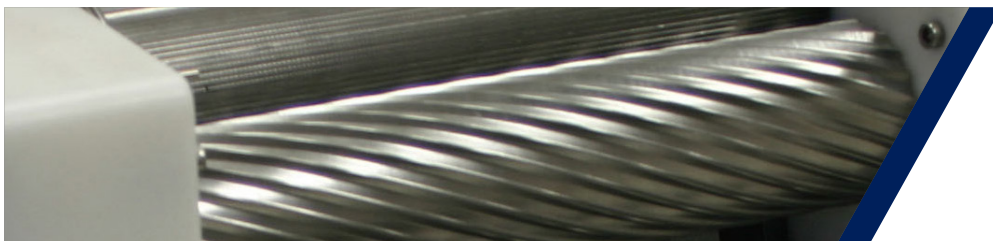

Visit our website

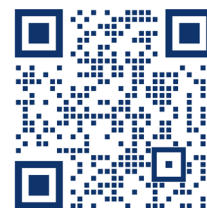



T 300F

Descamadora compacta para
pescado fresco.

Ofrece excelentes resultados a pesar de
su pequeño tamaño.

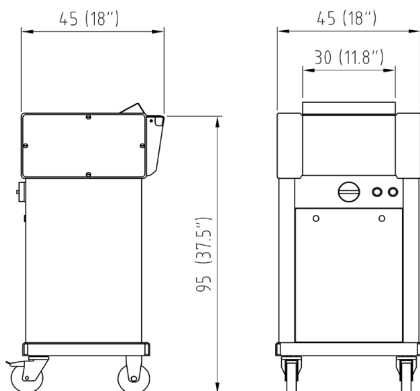

Datos Técnicos

	T300F
Height	980 mm / 38.58"
Width	450 mm / 17.72"
Depth	450 mm / 17.72"
Weight	104 Kg - 229.28 lb
Motor Power	0.37 Kw
Noise Level	71 db
Maximum working width	300 mm / 11.81"
Work Speed	24m/min - 80.6 ft/min
Operator control circuit	24V
Water consumption*	4lt/min

*optional



1. Superficie de trabajo ergonómica

Área de trabajo ergonómica y superficie de trabajo sin obstáculos para una mejor manipulación del producto durante el procesamiento.



2. Colóquelo donde quiera

Con sus dimensiones compactas, la T300 F requiere un espacio mínimo y es ideal para comercios y cocinas grandes.



3. Fácil de desinfectar

Extremadamente fácil de limpiar, sin necesidad de preparar herramientas de desinfección.



4. Procesamiento eficiente y limpio

La T300F está equipada con un recipiente para recoger la piel y evitar que se caiga, permitiendo la salida del agua utilizada durante el procesamiento.



6. Duradero en el tiempo

Rodillo dentado endurecido para aumentar la vida útil de los componentes y reducir el mantenimiento.

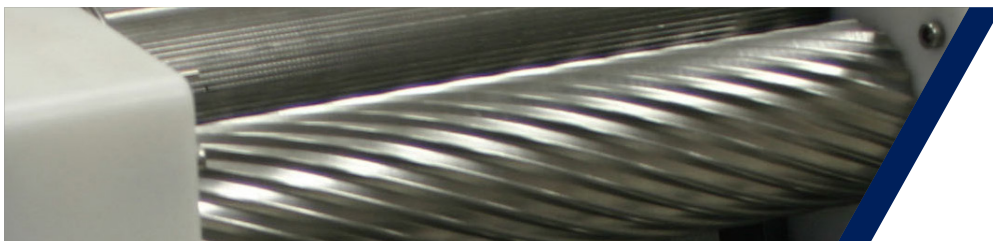

Visit our website

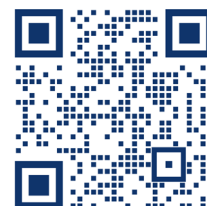

KOMPAKTSCHÄLER FÜR FRISCHEN FISCH



T 300F

Kompakter Schäler für frischen Fisch.

Trotz seiner geringen Größe liefert er hervorragende Ergebnisse.

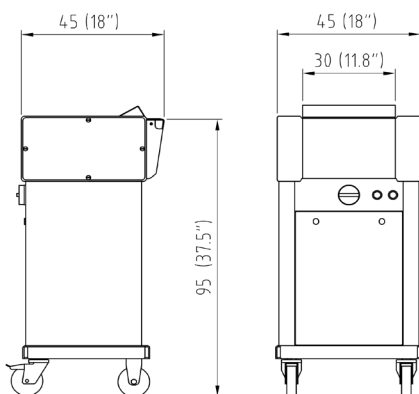

Technische Daten

	T300F
Height	980 mm / 38.58"
Width	450 mm / 17.72"
Depth	450 mm / 17.72"
Weight	104 Kg - 229.28 lb
Motor Power	0.37 Kw
Noise Level	71 db
Maximum working width	300 mm / 11.81"
Work Speed	24m/min - 80.6 ft/min
Operator control circuit	24V
Water consumption*	4lt/min

*optional

T300F

KOMPAKTSCHÄLER FÜR FRISCHEN FISCH



1. Ergonomische Arbeitsfläche

Ergonomischer Arbeitsbereich und freie Arbeitsfläche zur besseren Handhabung des Produkts während der Verarbeitung.



2. Platzieren Sie es, wo immer Sie wollen

Mit seinen kompakten Abmessungen benötigt die T300 F nur wenig Platz und ist ideal für Geschäfte und Großküchen.



3. Leichte Desinfektion

Extrem leicht zu reinigen, ohne dass Desinfektionsmittel benötigt werden.



4. Effiziente und saubere Verarbeitung

Die T300F ist mit einem Auffangbehälter für die Schale ausgestattet, um zu verhindern, dass diese herunterfällt, so dass das bei der Verarbeitung verwendete Wasser abfließen kann.



5. Langlebige, gehärtete Zahnwalze

Für eine längere Lebensdauer der Komponenten und geringeren Wartungsaufwand.

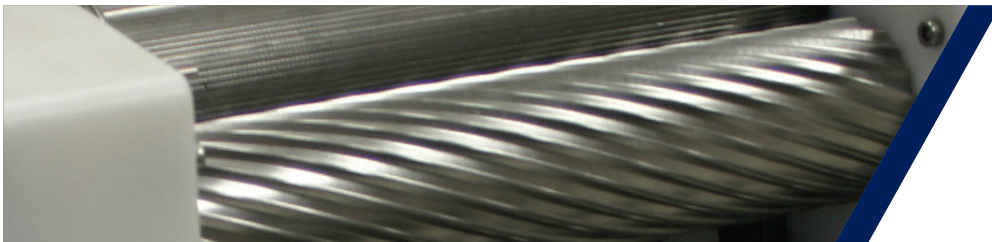

Visit our website



MACHINE À PELER COMPACTE POUR LES POISSONS FRAIS



T 300F

Une machine à peler compacte pour les poissons frais.

Elle donne d'excellents résultats malgré sa petite taille.

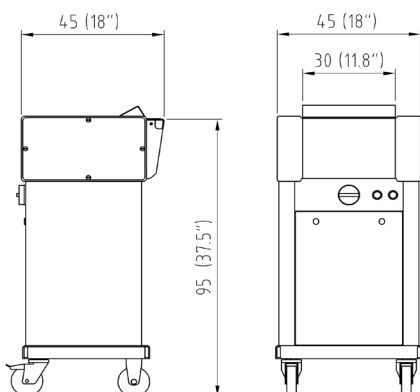

Données techniques

	T300F
Height	980 mm / 38.58"
Width	450 mm / 17.72"
Depth	450 mm / 17.72"
Weight	104 Kg - 229.28 lb
Motor Power	0.37 Kw
Noise Level	71 db
Maximum working width	300 mm / 11.81"
Work Speed	24m/min - 80.6 ft/min
Operator control circuit	24V
Water consumption*	4lt/min

*optional



1. Surface de travail ergonomique

Zone de travail ergonomique et surface de travail dégagée pour une meilleure manipulation des produits pendant le traitement.



2. Placez-le où vous voulez

Avec ses dimensions compactes, la T300 F nécessite un espace minimal et est idéale pour les magasins et les grandes cuisines.



3. Nettoyage facile

Extrêmement facile à nettoyer, sans avoir besoin de préparer des outils d'assainissement.



4. Traitement efficace et propre

La T300F est équipée d'un récipient destiné à recueillir la peau pour éviter qu'elle ne tombe, ce qui permet d'évacuer l'eau utilisée pendant le traitement.



5. Longue durée

Rouleau denté trempé pour augmenter la durée de vie des composants et réduire la maintenance.

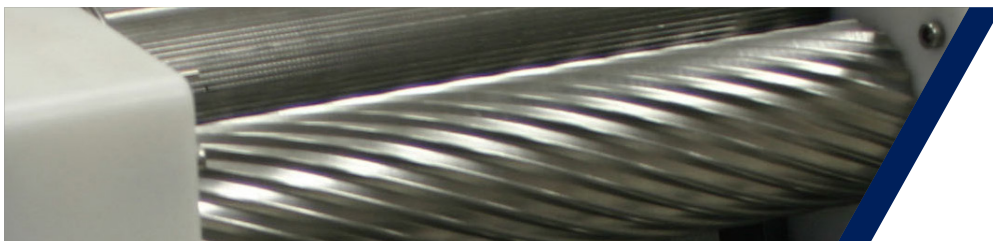

Visit our website

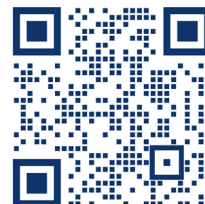



T 300F

Esfolador compacto para peixe fresco.

Apresenta excelentes resultados apesar do seu pequeno tamanho.

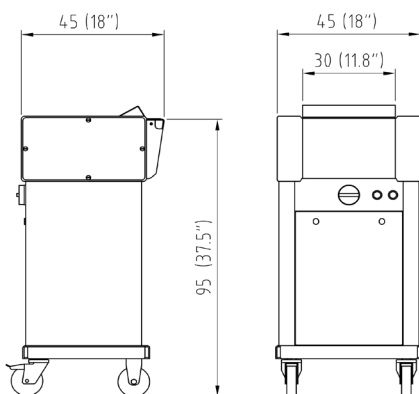

Dados Técnicos

	T300F
Height	980 mm / 38.58"
Width	450 mm / 17.72"
Depth	450 mm / 17.72"
Weight	104 Kg - 229.28 lb
Motor Power	0.37 Kw
Noise Level	71 db
Maximum working width	300 mm / 11.81"
Work Speed	24m/min - 80.6 ft/min
Operator control circuit	24V
Water consumption*	4lt/min

*optional



1. Bancada de trabalho ergonómica

Área de trabalho ergonómica e bancada de trabalho desobstruída para um melhor manuseamento do produto durante o processamento.



2. Coloque-a onde quiser

Com as suas dimensões compactas, a T300 F requer um espaço mínimo e é ideal para lojas e grandes cozinhas.



3. Fácil higienização

Extremamente fácil de limpar, sem a necessidade de preparar utensílios de higienização.



4. Processamento eficiente e limpo

T300F está equipada com um recipiente para recolher a pele para evitar a sua queda, permitindo que a água utilizada durante o processamento escoe.



5. Durável ao longo do tempo

Rolo dentado temperado para aumentar a vida útil dos componentes e reduzir a manutenção.

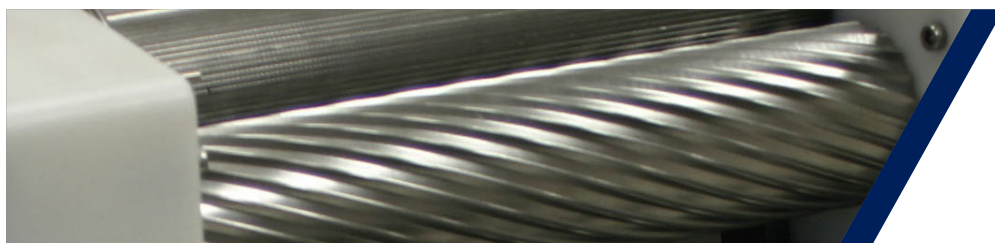

Visit our website

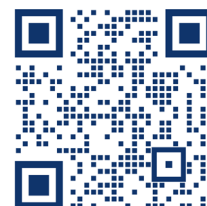

紧凑型去鱼皮机



T 300F

紧凑型去鱼皮机。

尽管尺寸很小, 但可保证出色的效果。

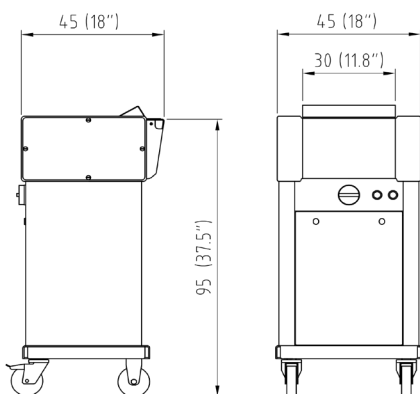

技术参数

	T300F
Height	980 mm / 38.58"
Width	450 mm / 17.72"
Depth	450 mm / 17.72"
Weight	104 Kg - 229.28 lb
Motor Power	0.37 Kw
Noise Level	71 db
Maximum working width	300 mm / 11.81"
Work Speed	24m/min - 80.6 ft/min
Operator control circuit	24V
Water consumption*	4lt/min

*optional

T300F

紧凑型去鱼皮机



1. 人体工学工作台

人体工学工作区域和工作台空间充足,可在加工过程中更好地处理产品。



2. 放在想要放的地方

T300 F 去鱼皮机结构紧凑,占用空间极小,适合于店铺和大厨房。



3. 易于实现卫生条件

极为容易清洁,无需准备消毒工具。



4. 高效、清洁的加工

T300F 配备一个收集鱼皮非容器,以防止掉落,同时允许加工过程中使用的水流出。



5. 经久耐用

淬火处理的齿辊,可延长部件的使用寿命并减少维护。

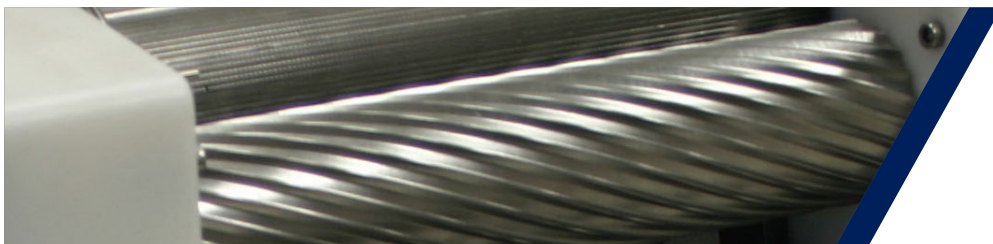

Visit our website



