

GLOBALLY RAISING THE STANDARDS OF FOOD THROUGH THE ART OF SLICING

# NAB 520/520 M

Automatic derinder  
and membrane skinner





## NAB 520 / 520 M

Scotennatrice e asportatrice di membrane totalmente automatica per soluzioni in linea.

Accuratezza e precisione anche con i tagli più delicati di carne suina e pollame.

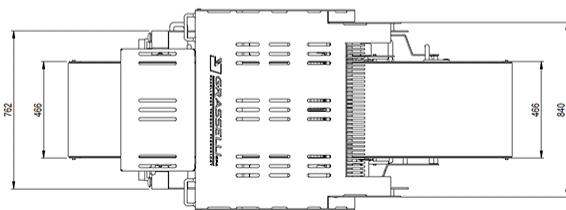
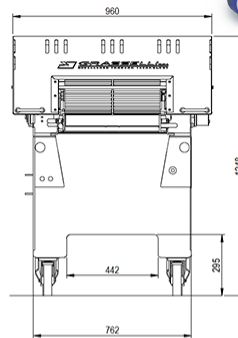
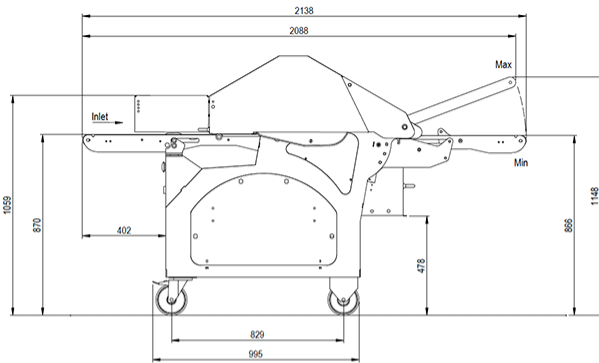

### Dati Tecnici

	NAB 520	NAB 520 M
Height	1249 mm / 49.2"	2148 mm / 49.13"
Width	971 mm / 38.2"	960 mm / 37.8"
Depth	2137 mm / 84.1"	2138 mm / 84.17"
Weight	480 Kg - 1.058 lbs	450 Kg - 992 lbs
Motor Power	1,8 Kw	2.2 Kw
Noise Level	75 db	75 db
Maximum working width	520 mm / 20.47"	520 mm / 20.47"
Operator Control Circuit	24V	24V
Air Consumption (M version)	42 lt/min	140 lt/min

# NAB 520 / 520 M

SCOTENNATRICE E ASPORTATRICE DI MEMBRANE AUTOMATICA



## 1. Scotennatura e rimozione di membrane efficienti

Grazie al nastro d'ingresso regolabile in relazione alle lame e al rullo dentato, NAB520 assicura operazioni di scotennatura e rimozione di membrana perfette.



## 2. Soluzione in linea

Grazie all'alimentazione totalmente automatica sia in ingresso che in uscita, NAB 520 è la soluzione automatizzata ideale per una lavorazione in linea, completa di nastro d'uscita regolabile in altezza.



## 3. Durata superiore

Rullo dentato esclusivo realizzato con acciaio speciale ad alta resistenza per una maggior durata ed efficienza costante nel tempo.



## 4. Pulizia facile e approfondita

Design all'avanguardia con saldatura continua ed angoli arrotondati per assicurare maggiore igiene senza l'ausilio di utensili. I nastri trasportatori possono essere aperti per un lavaggio perfetto e una migliore igienizzazione.



## 5. Massimizza la tua produttività

Diverse tipologie di rulli di pressatura prodotto controllati pneumaticamente e regolabili in altezza.



## 6. Facile accesso per la manutenzione

Tutte le principali componenti meccaniche ed elettriche sono accessibili attraverso due pannelli laterali, facilitando eventuali operazioni di manutenzione.



## 7. Costruzione solida

Il basamento della macchina è realizzato totalmente in acciaio inox extra-spesso, testato e certificato non radioattivo.



## 8. Modello DD disponibile

Il modello Grasselli NAB 520 DD è stato sviluppato specificatamente per la scotennatura e la rimozione di grasso ad uno spessore predeterminato, con il massimo dell'efficienza e controllo di resa, ideale per carni suine come lombi di maiale, pancetta e spalle.



Visit our website



## AUTOMATIC DERINDER AND MEMBRANE SKINNER



# NAB 520 / 520 M

Fully automatic derinder and membrane skinner for in-line solutions

Accuracy and precision with even the most delicate cuts of pork meat and poultry.

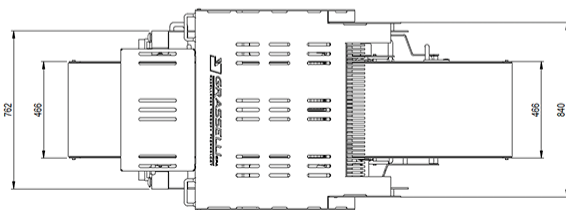
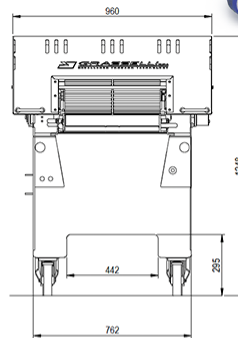
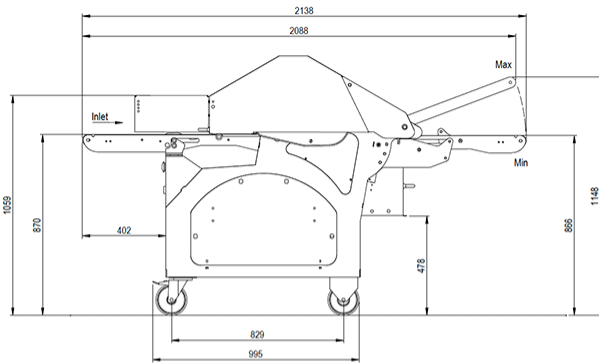

### Technical Data

	NAB 520	NAB 520 M
Height	1249 mm / 49.2"	2148 mm / 49.13"
Width	971 mm / 38.2"	960 mm / 37.8"
Depth	2137 mm / 84.1"	2138 mm / 84.17"
Weight	480 Kg - 1.058 lbs	450 Kg - 992 lbs
Motor Power	1,8 Kw	2.2 Kw
Noise Level	75 db	75 db
Maximum working width	520 mm / 20.47"	520 mm / 20.47"
Operator Control Circuit	24V	24V
Air Consumption (M version)	42 lt/min	140 lt/min

# NAB 520 / 520 M

## AUTOMATIC DERINDER AND MEMBRANE SKINNER



### 1. Efficient skinning and derinding

Thanks to the adjustable infeed belt in relation to blade and toothroll NAB520 ensures perfect skinning and derinding operations.



### 2. In-line solution

With fully automatic infeed and outfeed, NAB 520 is the ideal automated solution for in-line processing, complete with height-adjustable outfeed conveyor belt.



### 3. Superior Durability

Exclusive toothroller made from special high-resistance steel for greater durability and constant efficiency over time.



### 4. Easy and thorough cleaning

Cutting-edge design with continuous welding and rounded edges to ensure greater hygiene without the need for any tools. Conveyor belts can be opened for perfect washing and improved hygiene.



### 5. Maximize productivity

Product pressure roller with hydraulic control, fully adjustable, and various types of rubber rollers for all applications.



### 6. Easy access for maintainance

All major mechanical and electrical components are accessible through two side panels, making access easier for maintenance purposes.



### 7. Robust construction

Machine base made entirely in ultra-thick, food-grade non-radioactive stainless steel.



### 8. DD Model available

The Grasselli NAB 520 DD model is designed specifically for the derinding and removal of fat at a preset thickness, with the maximum efficiency and output control, for pork meats such as pork loin, bacon and shoulder.

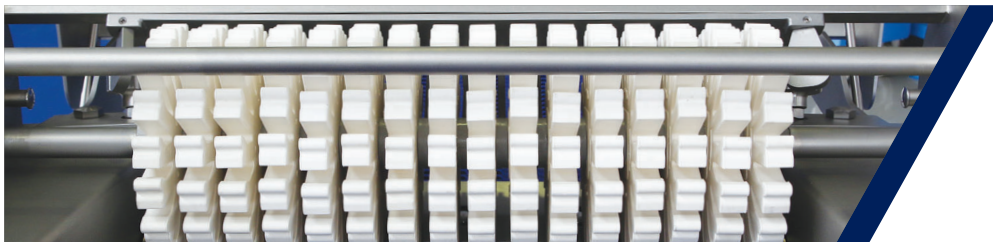

Visit our website





## NAB 520 / 520 M

Полностью автоматическое решение для удаления пленок и кожи в составе линии.

Точность и аккуратность даже при работе с самыми деликатными кусками свинины и мяса птицы.

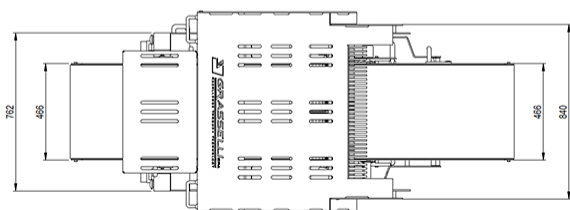
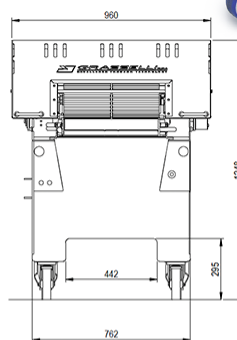
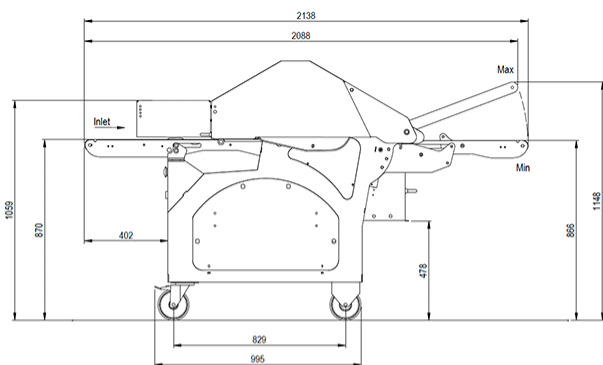

### Технические данные

	NAB 520	NAB 520 M
Height	1249 mm / 49.2"	2148 mm / 49.13"
Width	971 mm / 38.2"	960 mm / 37.8"
Depth	2137 mm / 84.1"	2138 mm / 84.17"
Weight	480 Kg - 1.058 lbs	450 Kg - 992 lbs
Motor Power	1,8 Kw	2.2 Kw
Noise Level	75 db	75 db
Maximum working width	520 mm / 20.47"	520 mm / 20.47"
Operator Control Circuit	24V	24V
Air Consumption (M version)	42 lt/min	140 lt/min

# NAB 520 / 520 M

АВТОМАТИЧЕСКАЯ МАШИНА ДЛЯ УДАЛЕНИЯ ПЛЕНОК



## 1. Эффективное удаление кожи и пленок

Благодаря возможности регулировки положения входного ленточного транспортера в соответствии с положением ножей и зубчатого вала NAB520 обеспечивает идеальное выполнение операций по удалению кожи и пленок.



## 2. Решение для работы в составе линии

Благодаря полностью автоматической подаче и выгрузке NAB 520 является идеальным автоматизированным решением для использования в составе линии, укомплектованным регулируемым по высоте выходным ленточным транспортером.



## 3. Увеличенный срок службы

Эксклюзивный зубчатый вал из специальной высокопрочной стали обеспечивает увеличение срока службы и неизменную с течением времени эффективность.



## 4. Простая и глубокая очистка

Современная конструкция с закругленными углами и непрерывными сварными швами обеспечивает лучшую дезинфекцию без использования инструментов. Ленточные транспортеры можно открыть для достижения оптимальных результатов мойки и повышения эффективности дезинфекции.



## 5. Доведите до максимума производительность вашего оборудования

Различные типы регулируемых по высоте роликов с пневматическим приводом для прижима продукта.



## 6. Легкий доступ для технического обслуживания

Все основные механические и электрические компоненты доступны после снятия двух боковых панелей, что облегчает проведение возможных операций по техническому обслуживанию.



## 7. Надежная конструкция

Станина машины полностью изготовлена из проверенной и сертифицированной в качестве нерадиоактивной нержавеющей стали особо большой толщины.



## 8. Доступна модель DD

Модель Grasselli NAB 520 DD разработана специально для удаления кожи и жира с заданной толщиной, с максимальной эффективностью и контролем выхода, и является идеальным решением для таких продуктов из свинины как вырезка, грудинка и окорок.



Visit our website

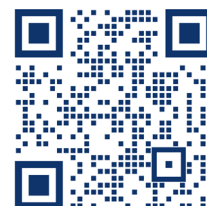



# NAB 520 / 520 M

Peladora y desveladoras totalmente automática para soluciones en línea.

Exactitud y precisión incluso con los cortes más delicados de carne de cerdo y ave.

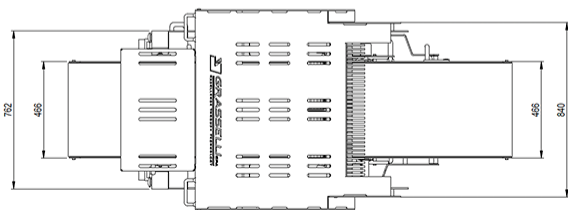
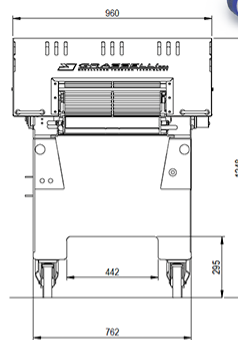
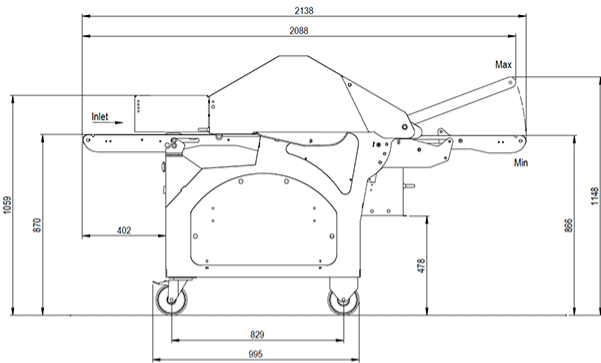

## Datos Técnicos

	NAB 520	NAB 520 M
Height	1249 mm / 49.2	2148 mm / 49.13"
Width	971 mm / 38.2"	960 mm / 37.8"
Depth	2137 mm / 84.1"	2138 mm / 84.17"
Weight	480 Kg - 1.058 lbs	450 Kg - 992 lbs
Motor Power	1,8 Kw	2.2 Kw
Noise Level	75 db	75 db
Maximum working width	520 mm / 20.47"	520 mm / 20.47"
Operator Control Circuit	24V	24V
Air Consumption (M version)	42 lt/min	140 lt/min

# NAB 520 / 520 M

PELADORA Y DESVELADORAS AUTOMÁTICA



## 1. Pelado y desvelado eficaz

Con su cinta de entrada ajustable en relación con las cuchillas y el rodillo dentado, la NAB520 garantiza unas operaciones perfectas de pelado y eliminación de membranas.



## 2. Solución en línea

Con su entrada y salida totalmente automáticas, la NAB 520 es la solución automatizada ideal para el procesamiento en línea, con una cinta de entrega de altura ajustable.



## 3. Durabilidad superior

Exclusivo rodillo dentado fabricado con acero especial de alta resistencia para una mayor durabilidad y eficiencia constante.



## 4. Limpieza fácil y completa

Diseño de vanguardia con cordón de soldadura continuo y esquinas redondeadas para garantizar una mayor higiene sin necesidad de herramientas. Las cintas transportadoras pueden abrirse para un lavado perfecto y una mejor desinfección.



## 5. Maximice su productividad

Diferentes tipos de rodillos de prensado de productos controlados neumáticamente y ajustables en altura.



## 6. Fácil acceso para el mantenimiento

Todos los componentes mecánicos y eléctricos principales son accesibles a través de dos paneles laterales, lo que facilita cualquier operación de mantenimiento.



## 7. Construcción sólida

La bancada de la máquina está fabricada íntegramente en acero inoxidable extragrueso, probado y certificado como no radiactivo.



## 8. Modelo DD disponible

El modelo Grasselli NAB 520 DD se ha desarrollado específicamente para el desvelado y la eliminación de la grasa hasta un grosor predeterminado, con la máxima eficacia y control del rendimiento, ideal para la carne de cerdo, como lomos, bacon y paletillas.



Visit our website



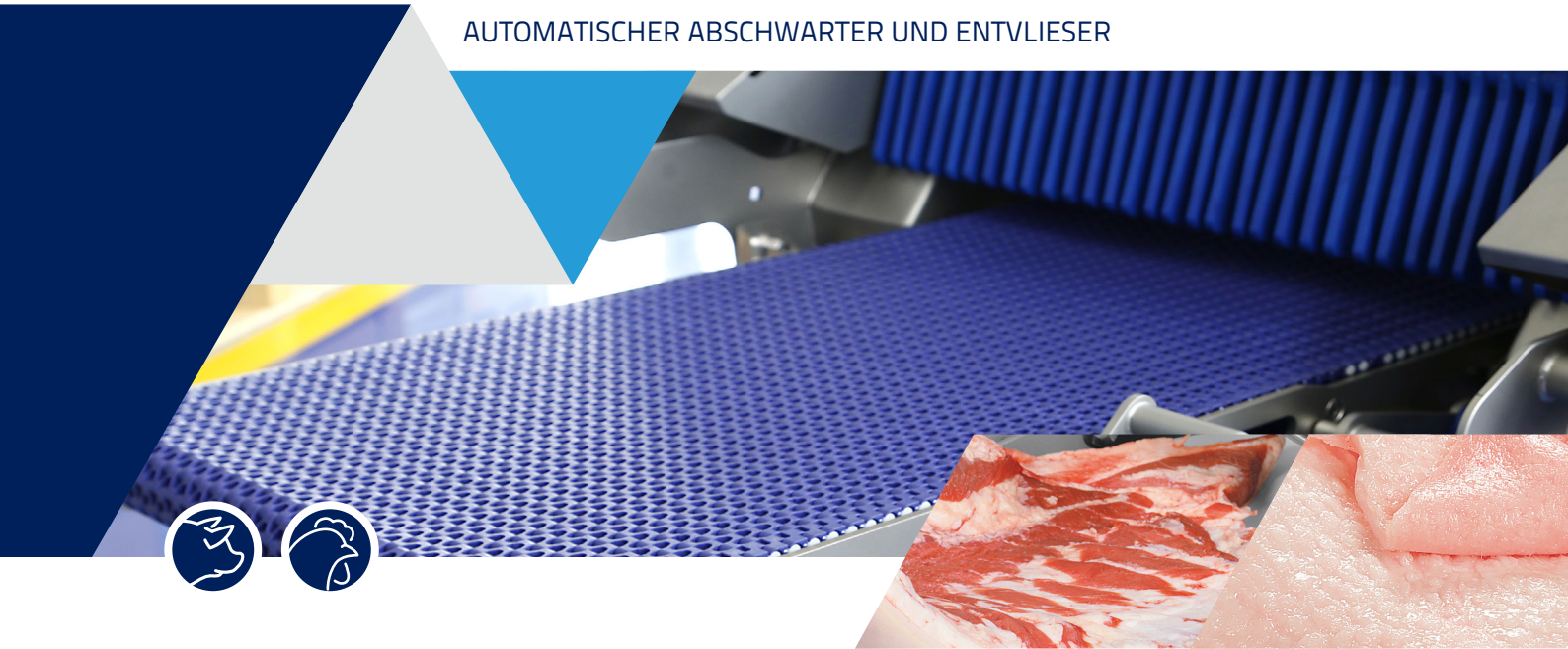

# NAB 520 / 520 M

Vollautomatischer Abschwarter und Entvlieser für Inline-Lösungen.

Genauigkeit und Präzision auch bei den empfindlichsten Teilen von Schweinefleisch und Geflügel.

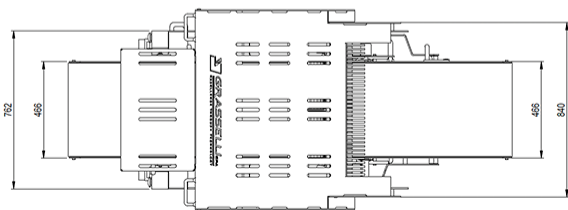
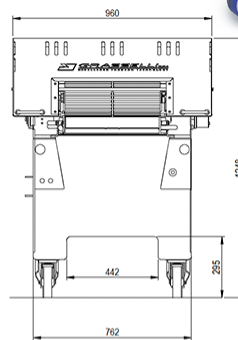
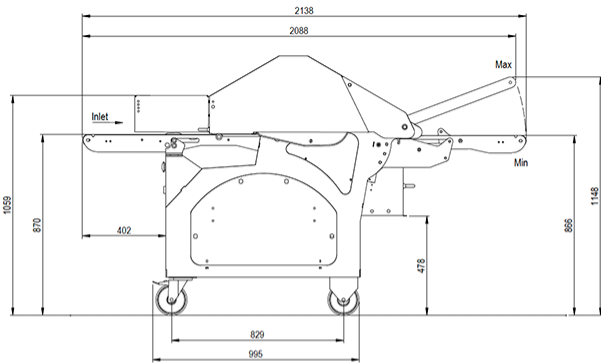

## Technische Daten

	NAB 520	NAB 520 M
Height	1249 mm / 49.2	2148 mm / 49.13"
Width	971 mm / 38.2"	960 mm / 37.8"
Depth	2137 mm / 84.1"	2138 mm / 84.17"
Weight	480 Kg - 1.058 lbs	450 Kg - 992 lbs
Motor Power	1,8 Kw	2.2 Kw
Noise Level	75 db	75 db
Maximum working width	520 mm / 20.47"	520 mm / 20.47"
Operator Control Circuit	24V	24V
Air Consumption (M version)	42 lt/min	140 lt/min

# NAB 520 / 520 M

## AUTOMATISCHER ABSCHWARTER UND ENTVLIESER



### 1. Effizienter Abschwarter und Entvliesser

Mit seinem im Verhältnis zu den Messern und der Zugwalze verstellbaren Einlaufband, gewährleistet die NAB520 perfekte Abschwart- und Entvliessvorgänge.



### 2. In-line Lösung

Mit ihrem vollautomatischen Ein- und höhenverstellbaren Auslauf ist die NAB 520 die ideale automatisierte Lösung für die Inline-Verarbeitung.



### 3. Lange Lebensdauer

Zugwalze aus hochfestem Spezialstahl für eine noch längere Einsatzzeit und konstanter Effizienz.



### 4. Einfache und gründliche Reinigung

Modernes Design mit durchgehenden Schweißnähten und abgerundeten Kanten für mehr Hygiene. Die Förderbänder können für eine perfekte Reinigung geöffnet werden.



### 5. Maximieren Sie Ihre Produktionsleistung

Verschiedene Typen von pneumatisch gesteuerten und höhenverstellbaren Andruckwalzen verfügbar.



### 6. Einfacher Zugang für die Wartung

Alle wichtigen mechanischen und elektrischen Komponenten sind über zwei Seitenwände zugänglich, was die Wartungsarbeiten erleichtert.



### 7. Solide Konstruktion

Das Maschinengestell ist vollständig aus extra dickem und zertifiziertem Edelstahl gefertigt.



### 8. DD-Modell verfügbar

Das Modell NAB 520 DD von Grasselli wurde speziell für das hocheffiziente Abschwarten und das Entfernen von Fett bis zu einer bestimmten Dicke entwickelt. Ideal für Schweinefleisch wie z.B. Koteletts, Speck und Schultern.



Visit our website



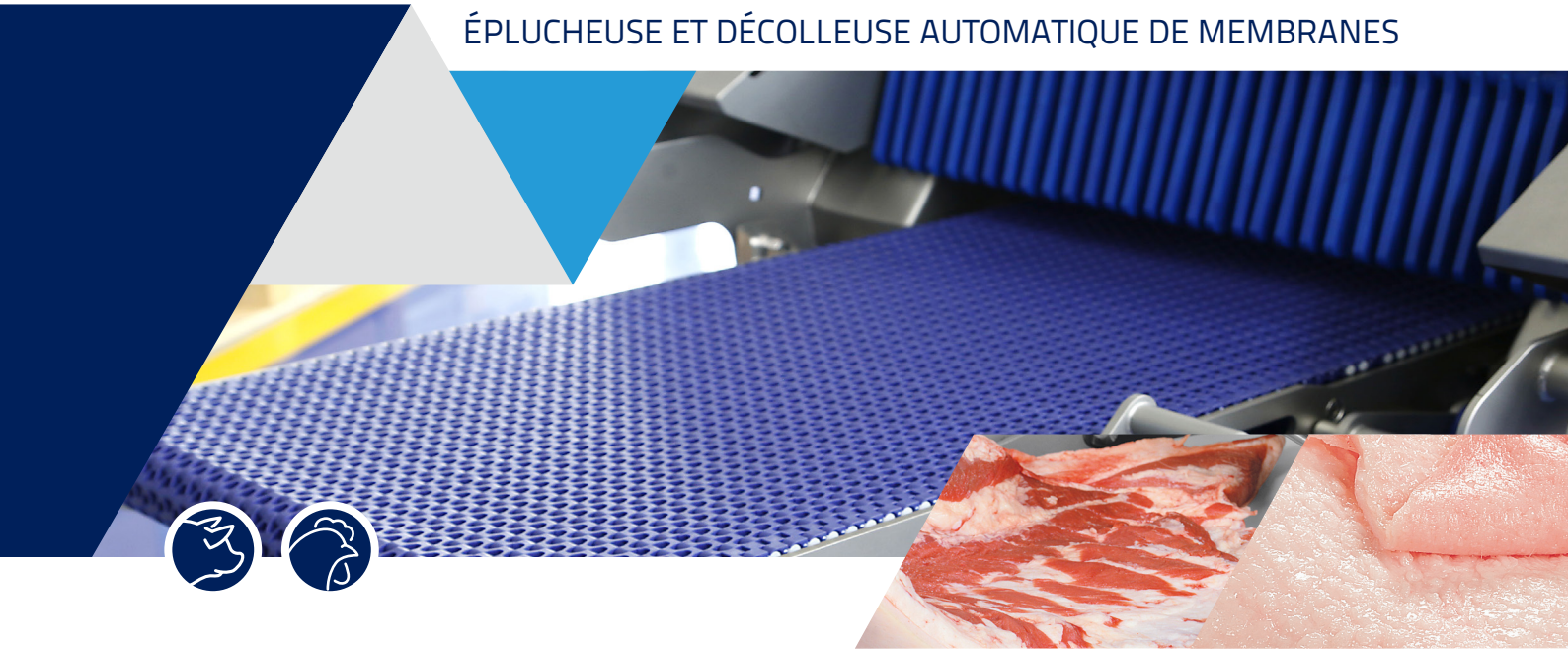

## NAB 520 / 520 M

Éplucheuse et décolleuse de membranes entièrement automatique pour les solutions en ligne.

Précision et exactitude même pour les coupes les plus délicates de viande de porc et de volaille.

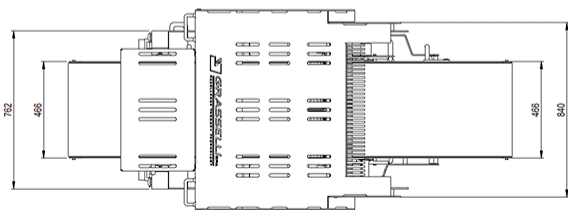
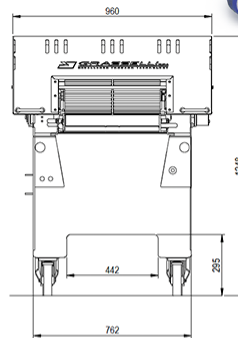
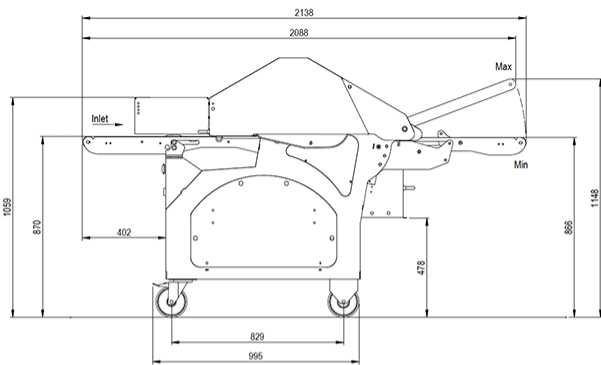

### Données techniques

	NAB 520	NAB 520 M
Height	1249 mm / 49.2	2148 mm / 49.13"
Width	971 mm / 38.2"	960 mm / 37.8"
Depth	2137 mm / 84.1"	2138 mm / 84.17"
Weight	480 Kg - 1.058 lbs	450 Kg - 992 lbs
Motor Power	1,8 Kw	2.2 Kw
Noise Level	75 db	75 db
Maximum working width	520 mm / 20.47"	520 mm / 20.47"
Operator Control Circuit	24V	24V
Air Consumption (M version)	42 lt/min	140 lt/min

# NAB 520 / 520 M

## ÉPLUCHEUSE ET DÉCOLLEUSE AUTOMATIQUE DE MEMBRANES



### 1. Épluchage et élimination de la membrane efficaces

Grâce à son ruban d'alimentation réglable par rapport aux lames et au rouleau denté, le NAB520 assure la perfection des opérations d'épluchage et d'élimination des membranes.



### 2. Solution en ligne

Avec son entrée et sa sortie entièrement automatiques, le NAB 520 est la solution automatisée idéale pour le traitement en ligne, avec un ruban de sortie réglable en hauteur.



### 3. Durabilité supérieure

Rouleau denté exclusif fabriqué en acier spécial à haute résistance pour une durabilité supérieure et une efficacité constante.



### 4. Nettoyage facile et complet

Conception de pointe avec soudure continue et coins arrondis pour assurer une meilleure hygiène sans outils. Les rubans peuvent être ouverts pour un lavage parfait et une meilleure désinfection.



### 5. Optimisez votre productivité

Différents types de rouleaux presseurs de produits à commande pneumatique et réglables en hauteur.



### 6. Accès facile pour la maintenance

Tous les principaux composants mécaniques et électriques sont accessibles à travers deux panneaux latéraux, facilitant ainsi toute opération de maintenance.



### 7. Construction solide

Le banc de la machine est entièrement fabriqué en acier inoxydable très épais, testé et certifié non radioactif.



### 8. Modèle DD disponible

Le modèle NAB 520 DD de Grasselli a été développé spécifiquement pour l'épluchage et l'enlèvement du gras à une épaisseur prédéterminée, avec une efficacité maximale et un contrôle du rendement, idéal pour la viande de porc telle que les longes, le bacon et les épaules.

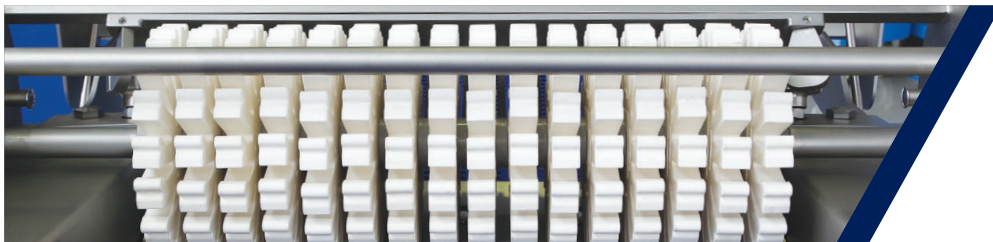

Visit our website



## ESFOLADOR E ESCALADOR AUTOMÁTICO



# NAB 520 / 520 M

Esfolador e escalador totalmente automático para soluções em linha.

Cuidado e precisão mesmo com os cortes mais delicados de carne de porco e de aves.

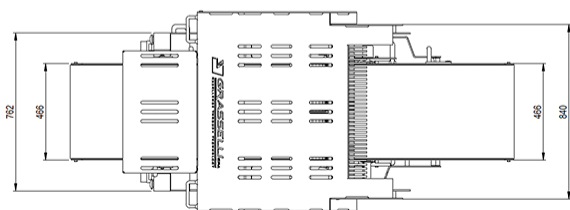
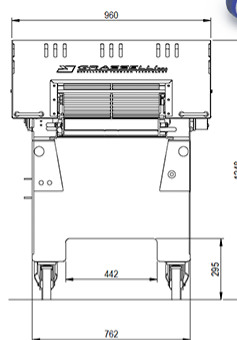
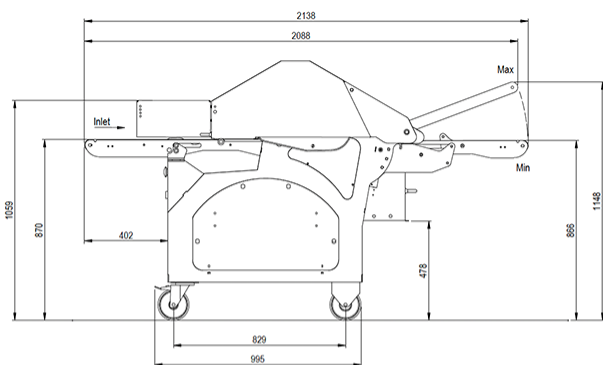

### Dados Técnicos

	NAB 520	NAB 520 M
Height	1249 mm / 49.2"	21248 mm / 49.13"
Width	971 mm / 38.2"	960 mm / 37.8"
Depth	2137 mm / 84.1"	2138 mm / 84.17"
Weight	480 Kg - 1.058 lbs	450 Kg - 992 lbs
Motor Power	1,8 Kw	2.2 Kw
Noise Level	75 db	75 db
Maximum working width	520 mm / 20.47"	520 mm / 20.47"
Operator Control Circuit	24V	24V
Air Consumption (M version)	42 lt/min	140 lt/min

# NAB 520 / 520 M

ESFOLADOR E ESCALADOR AUTOMÁTICO



## 1. Esfolamento e escalamento eficientes

Com o seu tapete de alimentação ajustável em relação às lâminas e ao rolo dentado, o NAB520 assegura operações perfeitas de esfolamento e escalamento.



## 2. Solução em linha

Com a sua alimentação totalmente automática de entrada e saída, o NAB 520 é a solução automatizada ideal para o processamento em linha, completo com um tapete de entrega com altura regulável.



## 3. Durabilidade superior

Rolo dentado exclusivo feito de aço especial de alta resistência para uma durabilidade superior e eficiência constante ao longo do tempo.



## 4. Limpeza fácil e completa

Desenho de vanguarda com soldadura contínua e cantos arredondados para assegurar uma maior higiene sem ferramentas. Os tapetes transportadores podem ser abertos para uma lavagem perfeita e uma melhor higienização.



## 5. Maximize a sua produtividade

Diferentes tipos de rolos de prensagem de produtos com controlo pneumático e reguláveis em altura.



## 6. Fácil acesso para manutenção

Todos os principais componentes mecânicos e elétricos são acessíveis através de dois painéis laterais, facilitando quaisquer operações de manutenção.



## 7. Construção sólida

A base da máquina é inteiramente feita de aço inoxidável extra-espesso, testado e certificado como não radioativo.



## 8. Modelo DD disponível

O modelo Grasselli NAB 520 DD foi desenvolvido especificamente para esfolar e remover gordura a uma espessura pré-determinada, com a máxima eficiência e controlo de rendimento, ideal para carne de porco como lombos, toucinho e ombros de porco.



Visit our website



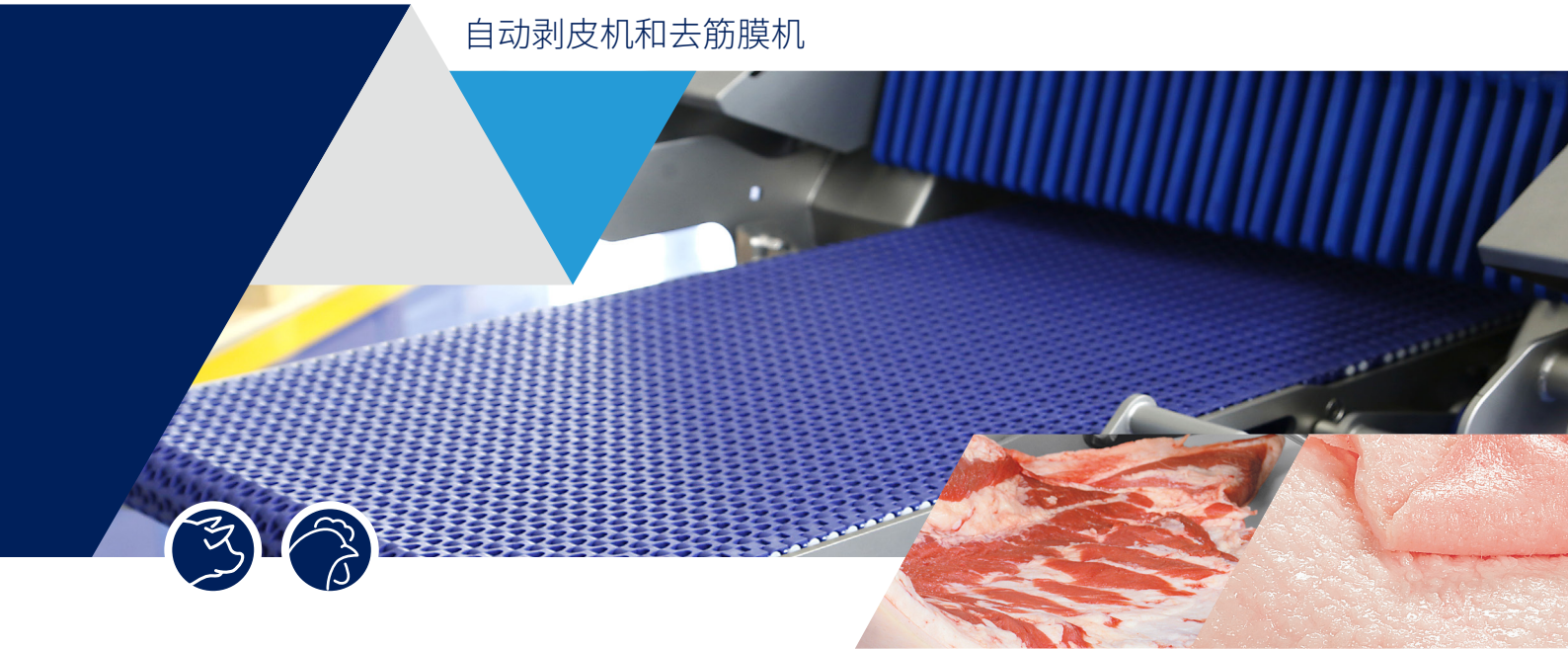

# NAB 520 / 520 M

生产线用全自动剥皮机和去筋膜机。  
即使是最精细的猪肉和家禽切割,也能够确保准确性和精度。

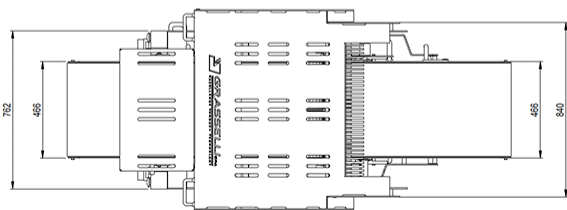
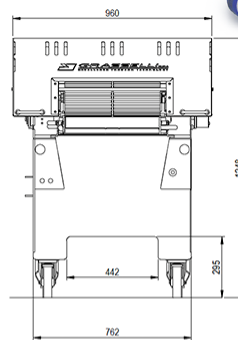
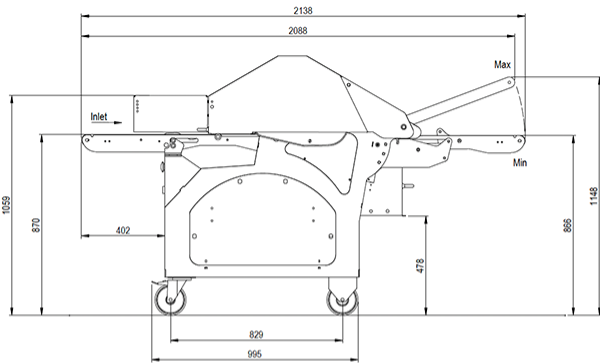

## 技术参数

	NAB 520	NAB 520 M
Height	1249 mm / 49.2	21248 mm / 49.13"
Width	971 mm / 38.2"	960 mm / 37.8"
Depth	2137 mm / 84.1"	2138 mm / 84.17"
Weight	480 Kg - 1.058 lbs	450 Kg - 992 lbs
Motor Power	1,8 Kw	2.2 Kw
Noise Level	75 db	75 db
Maximum working width	520 mm / 20.47"	520 mm / 20.47"
Operator Control Circuit	24V	24V
Air Consumption (M version)	42 lt/min	140 lt/min

# NAB 520 / 520 M

自动剥皮机和去筋膜机



## 1. 高效的剥皮和去筋膜

凭借可根据刀片和齿辊调整的输入传送带, NAB520 确保完美的剥皮和去筋膜操作。



## 2. 生产线方案

凭借输入和输出的全自动进料, NAB 520 是自动生产线加工的理想方案, 配有高度可调节的输出传送带。



## 3. 更长的使用寿命

独家齿辊采用特殊高强度钢制成, 使用寿命更长, 效率长期稳定。



## 4. 轻松、彻底的清洁

采用无缝焊接和圆角的尖端设计, 确保良好的卫生条件, 并且无需使用工具即可完成清洁。传送带可打开, 便于彻底的清洁和创造更高的卫生条件。



## 5. 获得最大的生产效率

不同类型的产品压辊气动控制和高度可调整。



## 6. 维护方便

通过两个侧板可维护所有主要机械和电气部件, 方便任何维护操作。



## 7. 坚固的结构

机器的底座完全由厚不锈钢制成, 经过测试和认证为无放射性。



## 8. 可提供 DD 型号

Grasselli NAB 520 DD 型号拥有高效率和产量, 专为以预设厚度对猪肉进行剥皮和脱脂而开发, 适用于里脊、五花肉和猪肩肉。

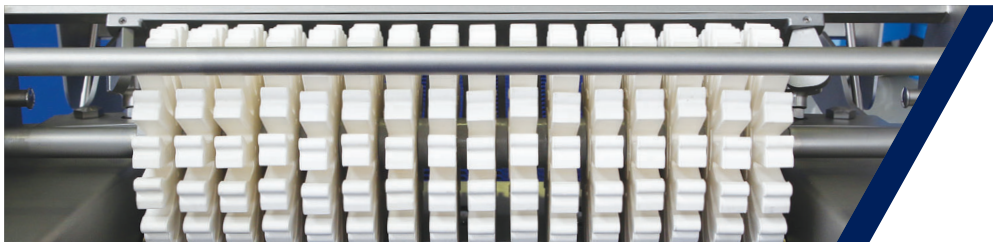

Visit our website



