

GLOBALLY RAISING THE STANDARDS OF FOOD THROUGH THE ART OF SLICING

GRASSELLI^{SPA}
NSL600

NSL

Semi-automatic vertical slicer



TAGLIAFETTINE VERTICALE SEMI-AUTOMATICA

GRASSELLI^{SPA}
NSL 600



NSL

Tagliafettine verticale per il taglio di fette perfette di carne, grazie al sistema di taglio multi-lama Grasselli.

Estrema precisione e qualità persino con gli spessori più sottili, in aggiunta all'alta produttività e agli alti rendimenti: lo standard di mercato delle tagliafettine verticali per carne fresca.

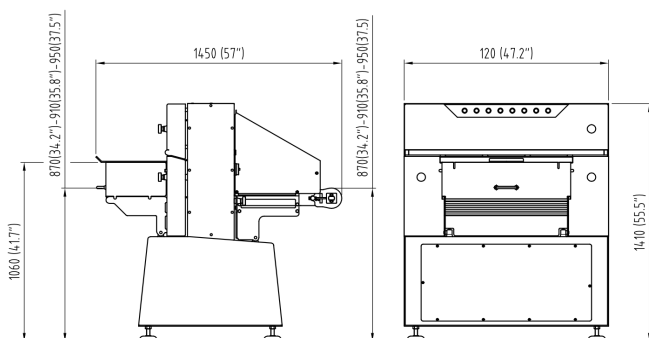

Dati Tecnici

	NSL 400	NSL 600	NSL 800	NSL 1000
Height	1410 mm / 55.50"	1410 mm / 55.50"	1410 mm / 55.50"	1410 mm / 55.50"
Width	986 mm / 38.82"	1200 mm / 47.24"	1382 mm / 54.40"	1558 mm / 61.34"
Depth	1450 mm / 57.09"	1450 mm / 57.09"	1450 mm / 57.09"	1595 mm / 68.80"
Weight	650 Kg - 1433 lbs	750 Kg / 1653.47 lbs	800 Kg / 1763.7 lbs	1020 Kg / 2248.7 lbs
Motor Power	4.2 Kw / 5.5 Kw	4.2 Kw / 5.5 Kw	5.5 Kw	5.5 Kw
Noise Level	71 db	71 db	71 db	71 lb
Maximum working width	396 mm / 15.59"	610 mm / 24.02"	792 mm / 31.20"	990 mm / 38.98"
Operator control circuit	24V	24V	24V	24V
Minimum slicing pitch bone-in	10 mm / 0.39"	10 mm / 0.39"	10 mm / 0.39"	12 mm / 0.47"
Minimum slicing pitch boneless	2.5 mm / 0.09"	3 mm / 0.12"	6.5 mm / 0.26"	10 mm / 0.39"
Air consumption	10 l/min	10 l/min	10 l/min	10 l/min

**1. Ideale per più applicazioni**

Lo standard di mercato delle tagliafettine verticali con centinaia di macchine vendute in tutto il Mondo, NSL riesce a tagliare prodotti freschi a temperatura positiva o congelati superficialmente (fino a -4 -5 gradi), sia con osso che senz'osso senza la produzione di schegge.

**2. Risparmia tempo nelle regolazioni meccaniche**

Sistema di cambio rapido lame opzionale per sostituire l'intero set di lame in pochi minuti, facilitato anche dal sistema di tensionamento delle lame automatizzato.

**3. Estremamente adattabile per il massimo delle prestazioni**

Con una vasta gamma di opzioni di taglio, i parametri di taglio NSL possono essere regolati per consentire la quantità massima del prodotto tagliato.

**4. Produttività comprovata sul campo**

NSL ha dimostrato di poter ottenere una capacità di taglio fino a 2.000Kg/h in base alle condizioni del prodotto.

**5. Soluzioni speciali disponibili su richiesta**

La camera di taglio può essere realizzata su misura per andare incontro alle specifiche caratteristiche del prodotto, ad esempio con spessori di taglio differenziati.

**6. Opzione Spintore passante**

NSL può essere dotata di Pusher personalizzati, progettati per adattarsi alla forma e alla posizione di caricamento, con lo scopo di ottenere un risultato finale di fette precise raggruppate in base all'aspetto originale del prodotto.

**7. Opzione Bone-In (BI)**

Versione BI disponibile per prodotti con osso, con un sistema di pressatura prodotto frazionato e lama dedicata.

**8. Facile sanificazione senza utensili**

Ottieni una sanificazione perfetta, senza utensili necessari sia per le operazioni di lavaggio che di sostituzione delle lame.

**9. Costruzione solida**

Il telaio della macchina è costruito in acciaio inox controllato e certificato non radioattivo per assicurare un'igienizzazione superiore e maggiore longevità.



Visit our website

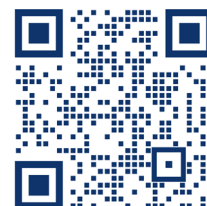

SEMI-AUTOMATIC VERTICAL SLICER

GRASSELLI^{SPA}
NSL 600



NSL

Vertical meat slicer for obtaining perfect slices, thanks to the Grasselli multi-blade cutting system.

Extreme precision and quality even for thinner slices, in addition to high productivity and yields: the market standard for vertical slicing of fresh meat.

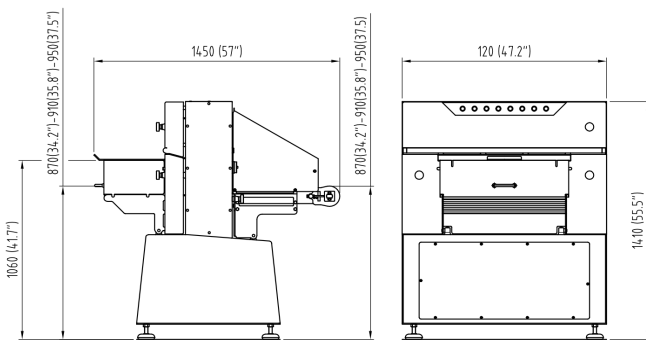

Technical Data

	NSL 400	NSL 600	NSL 800	NSL 1000
Height	1410 mm / 55.50"	1410 mm / 55.50"	1410 mm / 55.50"	1410 mm / 55.50"
Width	986 mm / 38.82"	1200 mm / 47.24"	1382 mm / 54.40"	1558 mm / 61.34"
Depth	1450 mm / 57.09"	1450 mm / 57.09"	1450 mm / 57.09"	1595 mm / 68.80"
Weight	650 Kg - 1433 lbs	750 Kg / 1653.47 lbs	800 Kg / 1763.7 lbs	1020 Kg / 2248.7 lbs
Motor Power	4.2 Kw / 5.5 Kw	4.2 Kw / 5.5 Kw	5.5 Kw	5.5 Kw
Noise Level	71 db	71 db	71 db	71 lb
Maximum working width	396 mm / 15.59"	610 mm / 24.02"	792 mm / 31.20"	990 mm / 38.98"
Operator control circuit	24V	24V	24V	24V
Minimum slicing pitch bone-in	10 mm / 0.39"	10 mm / 0.39"	10 mm / 0.39"	12 mm / 0.47"
Minimum slicing pitch boneless	2.5 mm / 0.09"	3 mm / 0.12"	6.5 mm / 0.26"	10 mm / 0.39"
Air consumption	10 l/min	10 l/min	10 l/min	10 l/min

**1. Ideal for a variety of applications**

As the market standard vertical slicer with hundreds of machines sold worldwide, NSL is able to slice fresh, positive temperature products or crust frozen ones (up to -4/-5 degrees), both boneless and bone-in, with no chipping.

**2. Save time on mechanical adjustments**

Optional quick blade changing system for replacing the entire set of blades in just a few minutes, also made easier by the automated blade tension adjustment system.

**3. Extremely adaptable for maximum performance**

With a wide range of cutting options, NSL's cutting parameters can be adjusted to allow for the maximum quantity of product to be sliced.

**4. Field proven productivity**

NSL has proven to deliver a cutting capacity of up to 2.000 Kg/h depending on the product conditions.

**5. Special solutions available on request**

The cutting chamber can be tailored to meet the product's specific characteristics, e.g. with differentiated cutting thicknesses.

**6. Through-pusher Option**

NSL can be equipped with personalized through-pushers designed to match the product's shape and infeed position, in order to obtain an end-result of neat slices grouped according to the original appearance of the product.

**7. Bone-In Option (BI)**

BI version available for bone-in products, with sectioned pressing system and dedicated blade.

**8. Easy sanitation without any tools**

Get perfect, thorough sanitation with no tools needed for either the cleaning operations and blades replacement.

**9. Robust construction**

The machine frame is made of food-grade non-radioactive stainless steel, to ensure for superior hygiene and longevity.



Visit our website

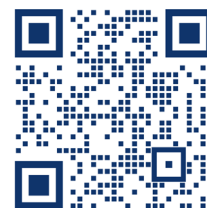

GRASSELLI^{SPA}
NSL 600



NSL

Вертикальная ломтерезка для нарезки идеальных ломтиков мяса благодаря многоножевой системе нарезки Grasselli.

Исключительная точность и качество даже при самой малой толщине в дополнение к высокой производительности и высокой эффективности: рыночный стандарт для вертикальных ломтерезок для свежего мяса.

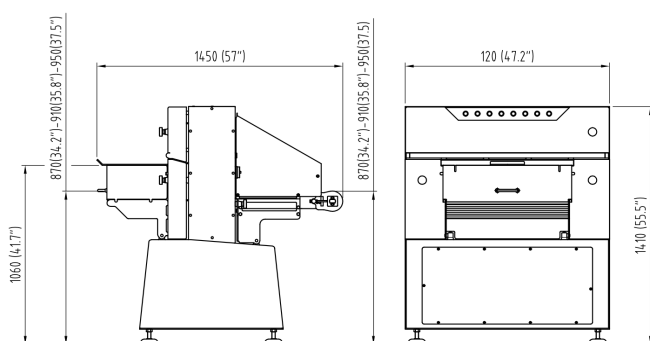

Технические данные

	NSL 400	NSL 600	NSL 800	NSL 1000
Height	1410 mm / 55.50"	1410 mm / 55.50"	1410 mm / 55.50"	1410 mm / 55.50"
Width	986 mm / 38.82"	1200 mm / 47.24"	1382 mm / 54.40"	1558 mm / 61.34"
Depth	1450 mm / 57.09"	1450 mm / 57.09"	1450 mm / 57.09"	1595 mm / 68.80"
Weight	650 Kg - 1433 lbs	750 Kg / 1653.47 lbs	800 Kg / 1763.7 lbs	1020 Kg / 2248.7 lbs
Motor Power	4.2 Kw / 5.5 Kw	4.2 Kw / 5.5 Kw	5.5 Kw	5.5 Kw
Noise Level	71 db	71 db	71 db	71 lb
Maximum working width	396 mm / 15.59"	610 mm / 24.02"	792 mm / 31.20"	990 mm / 38.98"
Operator control circuit	24V	24V	24V	24V
Minimum slicing pitch bone-in	10 mm / 0.39"	10 mm / 0.39"	10 mm / 0.39"	12 mm / 0.47"
Minimum slicing pitch boneless	2.5 mm / 0.09"	3 mm / 0.12"	6.5 mm / 0.26"	10 mm / 0.39"
Air consumption	10 l/min	10 l/min	10 l/min	10 l/min

**1. Идеально подходит для различных видов применения**

Являясь стандартом на рынке вертикальных ломтерезок с сотнями машин, проданных по всему миру, NSL способна нарезать находящиеся при положительной температуре свежие или поверхностно замороженные (до -4 -5 градусов) продукты, как с костями, так и без костей без образования осколков.

**2. Экономия времени на механическую регулировку**

Опциональная система быстрой смены ножей для замены всего комплекта ножей за считанные минуты, облегчаемой также благодаря автоматизированной системе натяжения ножей.

**3. Чрезвычайно высокая адаптируемость для достижения максимальной производительности**

Благодаря широкому ассортименту опций резки параметры машины NSA могут быть отрегулированы для достижения максимального выхода нарезанного продукта.

**4. Проверенная на практике производительность**

NSL доказала, что она может достигать производительности резки до 2000 кг/ч в зависимости от состояния продукта.

**5. Специальные решения доступны по специальному заказу**

Камера резки может быть изготовлена на заказ в соответствии с конкретными характеристиками продукта, например, с различными толщинами резки.

**6. Опция проходного толкателя**

NSL может быть оснащен персонализированными толкателями, разработанными с учетом формы и положения загрузки, с целью достижения конечного результата в виде точно нарезанных ломтиков, сгруппированных в соответствии с первоначальным видом продукта.

**7. вариант с косточкой (BI)**

Для продуктов с костями доступна версия BI с системой прессования фракционированного продукта и специальное лезвие.

**8. Простая дезинфекция без инструментов**

Воспользуйтесь возможностью идеальной дезинфекции без каких-либо инструментов как при мойке, так и при замене ножей.

**9. Надежная конструкция**

Станина машины изготовлена из проверенной и сертифицированной нерадиоактивной нержавеющей стали для повышения гигиеничности и увеличения срока службы.



Visit our website

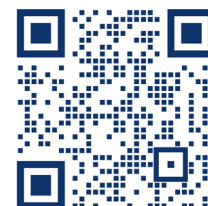

CORTADORA VERTICAL SEMIAUTOMÁTICA

GRASSELLI^{SPA}
NSL 600



NSL

Cortadora vertical para cortes perfectos de carne, gracias al sistema de corte multicuchilla de Grasselli. Precisión y calidad extremas incluso con los grosores más finos, además de una alta productividad y rendimiento: el estándar del mercado de cortadoras verticales para carne fresca.

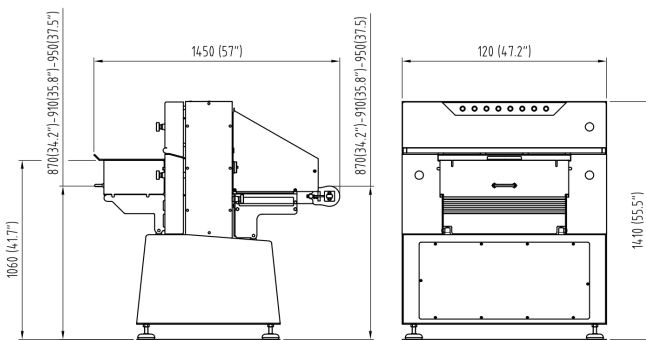

Datos Técnicos

	NSL 400	NSL 600	NSL 800	NSL 1000
Height	1410 mm / 55.50"	1410 mm / 55.50"	1410 mm / 55.50"	1410 mm / 55.50"
Width	986 mm / 38.82"	1200 mm / 47.24"	1382 mm / 54.40"	1558 mm / 61.34"
Depth	1450 mm / 57.09"	1450 mm / 57.09"	1450 mm / 57.09"	1595 mm / 68.80"
Weight	650 Kg - 1433 lbs	750 Kg / 1653.47 lbs	800 Kg / 1763.7 lbs	1020 Kg / 2248.7 lbs
Motor Power	4.2 Kw / 5.5 Kw	4.2 Kw / 5.5 Kw	5.5 Kw	5.5 Kw
Noise Level	71 db	71 db	71 db	71 lb
Maximum working width	396 mm / 15.59"	610 mm / 24.02"	792 mm / 31.20"	990 mm / 38.98"
Operator control circuit	24V	24V	24V	24V
Minimum slicing pitch bone-in	10 mm / 0.39"	10 mm / 0.39"	10 mm / 0.39"	12 mm / 0.47"
Minimum slicing pitch boneless	2.5 mm / 0.09"	3 mm / 0.12"	6.5 mm / 0.26"	10 mm / 0.39"
Air consumption	10 l/min	10 l/min	10 l/min	10 l/min

**1. Ideal para múltiples aplicaciones**

La NSL es el estándar del mercado de cortadoras horizontales, con cientos de máquinas vendidas en todo el mundo y capaz de cortar productos frescos o cocidos, a temperatura positiva o congelados superficialmente (hasta -4 -5 grados), tanto con hueso como sin hueso, sin producir astillas.

**2. Ahorro de tiempo en los ajustes mecánicos**

Sistema opcional de cambio rápido de cuchillas para cambiar todo el kit de cuchillas en cuestión de minutos, facilitado también por el sistema automático de tensión de las cuchillas.

**3. Extremadamente adaptable para un máximo rendimiento**

Con una amplia variedad de opciones de corte, los parámetros de corte de la NSL pueden ajustarse para permitir la máxima cantidad de producto cortado.

**4. Productividad probada en el campo**

La NSL ha demostrado que puede alcanzar una capacidad de corte de hasta 2000 kg/h dependiendo de las condiciones del producto.

**5. Soluciones especiales disponibles como opcional**

La cámara de corte puede adaptarse a las características específicas del producto, por ejemplo, con grosores de corte diferenciados.

**6. Opción de empujador pasante**

La NSL puede equiparse con empujadores personalizados, diseñados para adaptarse a la forma y posición de la carga, con el objetivo de conseguir un resultado final de cortes precisos agrupados según el aspecto original del producto.

**7. Opción con hueso (BI)**

Versión BI disponible para productos con hueso, con un sistema de prensado del producto fraccionado y cuchilla específica.

**8. Fácil desinfección sin herramientas**

Obtenga una perfecta desinfección sin necesidad de herramientas tanto para el lavado como para el cambio de cuchillas.

**9. Construcción sólida**

El chasis de la máquina está construido con acero inoxidable no radiactivo, probado y certificado, para garantizar una higiene y una longevidad superiores.



Visit our website

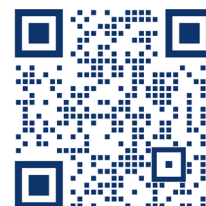

HALBAUTOMATISCHE VERTIKALE GATTER-SCHNEIDEMASCHINE

GRASSELLI^{SPA}
NSL 600



NSL

Vertikalschneider zum Schneiden von perfekt parallelen Scheiben dank des Grasselli-Gattermesser- Schneidsystems. Höchste Präzision und Qualität auch bei dünnsten Scheibenstärken sowie hohe Produktionsleistung und hohe Ausbeute: der Marktstandard bei Vertikalschneidern für Frischfleisch.

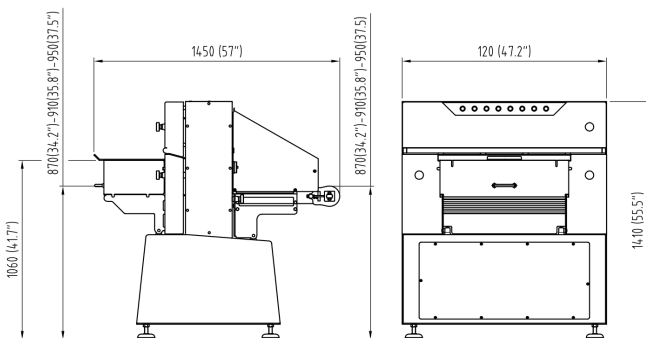

Technische Daten

	NSL 400	NSL 600	NSL 800	NSL 1000
Height	1410 mm / 55.50"	1410 mm / 55.50"	1410 mm / 55.50"	1410 mm / 55.50"
Width	986 mm / 38.82"	1200 mm / 47.24"	1382 mm / 54.40"	1558 mm / 61.34"
Depth	1450 mm / 57.09"	1450 mm / 57.09"	1450 mm / 57.09"	1595 mm / 68.80"
Weight	650 Kg - 1433 lbs	750 Kg / 1653.47 lbs	800 Kg / 1763.7 lbs	1020 Kg / 2248.7 lbs
Motor Power	4.2 Kw / 5.5 Kw	4.2 Kw / 5.5 Kw	5.5 Kw	5.5 Kw
Noise Level	71 db	71 db	71 db	71 lb
Maximum working width	396 mm / 15.59"	610 mm / 24.02"	792 mm / 31.20"	990 mm / 38.98"
Operator control circuit	24V	24V	24V	24V
Minimum slicing pitch bone-in	10 mm / 0.39"	10 mm / 0.39"	10 mm / 0.39"	12 mm / 0.47"
Minimum slicing pitch boneless	2.5 mm / 0.09"	3 mm / 0.12"	6.5 mm / 0.26"	10 mm / 0.39"
Air consumption	10 l/min	10 l/min	10 l/min	10 l/min



1. Ideal für mehrere Anwendungen

Als Marktstandard bei Vertikalschneidern mit Hunderten von weltweit verkauften Maschinen ist die NSL-Baureihe in der Lage, frische Produkte bei positiver Temperatur oder an der Oberfläche gefrostet (bis zu -4 -5 Grad) zu schneiden, sowohl mit als auch ohne Knochen, ohne dass dabei Splitter entstehen.



2. Spart Zeit bei mechanischen Einstellungen

Optionales Schnellwechselsystem für den Tausch des gesamten Messersatzes in Minutenschnelle. Das Messerspannsystem arbeitet automatisch und unterstützt den Messerwechsel.



3. Äußerst anpassungsfähig für maximale Leistung

Mit einer breiten Palette von Schneideoptionen können die NSL-Schneideparameter so eingestellt werden, dass die maximale Menge an geschnittenem Produkt erzielt wird.



4. Bewährte Produktionsleistung in der Praxis

Die NSL hat bewiesen, dass sie je nach Produktbedingungen eine Schneidleistung von bis zu 2.000 kg/h erreichen kann.



5. Sonderlösungen auf Anfrage erhältlich

Die Schneidkammer kann an spezifische Produkteigenschaften angepasst werden, z.B. mit unterschiedlichen Schnittstärken.



6. Optionaler Produktvorschub

Die NSL kann mit kundenspezifischen Vorschubbalken ausgestattet werden, die an die Form und Position des Schneidguts angepasst sind. Somit erzielen Sie hochpräzise Scheiben und lassen das Produkt in seiner ursprünglichen Form.



7. Option "Anbeinen" (BI)

BI-Version für Produkte mit Knochen inklusive aufgeteiltem Niederhaltesystem und spezielle Klinge.



8. Einfache Reinigung

Gründliche Maschinen- und Schneidsatzreinigung ohne Einsatz von Werkzeug.



9. Solide Konstruktion

Das äußerst stabile Maschinengehäuse ist aus geprüftem und zertifiziertem Edelstahl gefertigt und gewährleistet höchste Hygiene und Langlebigkeit.



Visit our website

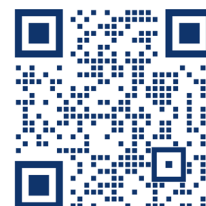

COUPEUR VERTICAL SEMI-AUTOMATIQUE

GRASSELLI^{SPA}
NSL 600



NSL

Coupeur vertical pour couper des tranches de viande parfaites, grâce au système de coupe multi-lames de Grasselli.

Une précision et une qualité extrêmes, même pour les épaisseurs les plus fines, en plus d'une productivité et de rendements élevés : la norme du marché des coupeurs verticaux pour la viande fraîche.

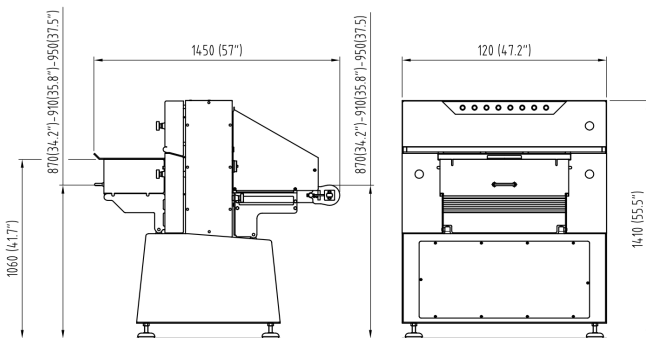

Données techniques

	NSL 400	NSL 600	NSL 800	NSL 1000
Height	1410 mm / 55.50"	1410 mm / 55.50"	1410 mm / 55.50"	1410 mm / 55.50"
Width	986 mm / 38.82"	1200 mm / 47.24"	1382 mm / 54.40"	1558 mm / 61.34"
Depth	1450 mm / 57.09"	1450 mm / 57.09"	1450 mm / 57.09"	1595 mm / 68.80"
Weight	650 Kg - 1433 lbs	750 Kg / 1653.47 lbs	800 Kg / 1763.7 lbs	1020 Kg / 2248.7 lbs
Motor Power	4.2 Kw / 5.5 Kw	4.2 Kw / 5.5 Kw	5.5 Kw	5.5 Kw
Noise Level	71 db	71 db	71 db	71 lb
Maximum working width	396 mm / 15.59"	610 mm / 24.02"	792 mm / 31.20"	990 mm / 38.98"
Operator control circuit	24V	24V	24V	24V
Minimum slicing pitch bone-in	10 mm / 0.39"	10 mm / 0.39"	10 mm / 0.39"	12 mm / 0.47"
Minimum slicing pitch boneless	2.5 mm / 0.09"	3 mm / 0.12"	6.5 mm / 0.26"	10 mm / 0.39"
Air consumption	10 l/min	10 l/min	10 l/min	10 l/min

**1. Idéal pour de multiples applications**

La norme du marché en matière de coupeurs verticaux, avec des centaines de machines vendues dans le monde, NSL est capable de couper des produits frais à température positive ou surgelés (jusqu'à -4 -5 degrés), avec ou sans os, sans produire d'échardes.

**2. Gain de temps sur les réglages mécaniques**

Système de changement rapide des lames en option pour changer l'ensemble des lames en quelques minutes, également facilité par le système de tension automatique des lames.

**3. Extrêmement adaptable pour une performance maximale**

Grâce à une large gamme d'options de coupe, les paramètres de coupe du NSL peuvent être ajustés pour permettre une quantité maximale de produit coupé.

**4. Une productivité éprouvée sur le terrain**

NSL a prouvé qu'il pouvait atteindre une capacité de coupe allant jusqu'à 2 000 kg/h selon les conditions du produit.

**5. Solutions spéciales disponibles sur demande**

La chambre de coupe peut être personnalisée pour répondre à des caractéristiques de produit spécifiques, par exemple avec des épaisseurs de coupe différenciées.

**6. Option de poussoir à passage**

NSL peut être équipé de poussoirs personnalisés, conçus pour s'adapter à la forme et à la position du chargement, dans le but d'obtenir un résultat final de tranches précises regroupées selon l'aspect du produit original.

**7. Option avec os (BI)**

Version BI disponible pour les produits avec os, avec un système de pressage des produits fractionnés et lame dédiée.

**8. Assainissement facile, sans outils**

Obtenez un assainissement parfait sans aucun outil, tant pour le lavage que pour le remplacement des lames.

**9. Construction solide**

Le châssis de la machine est construit en acier inoxydable non radioactif testé et certifié pour garantir une hygiène et une longévité supérieures.



Visit our website

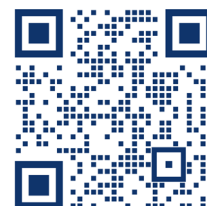

CORTADOR VERTICAL SEMI-AUTOMÁTICO

GRASSELLI^{SPA}
NSL 600



NSL

Cortador vertical para cortar fatias perfeitas de carne, graças ao sistema de corte multi-lâminas da Grasselli.

Extrema precisão e qualidade mesmo com as espessuras mais finas, para além de alta produtividade e altos rendimentos: o padrão de mercado para cortadores verticais para carne fresca.

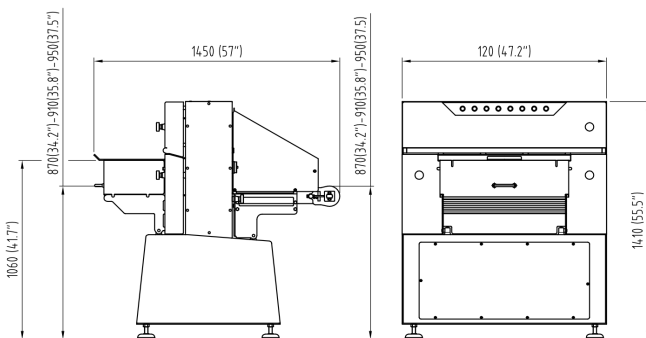

Dados Técnicos

	NSL 400	NSL 600	NSL 800	NSL 1000
Height	1410 mm / 55.50"	1410 mm / 55.50"	1410 mm / 55.50"	1410 mm / 55.50"
Width	986 mm / 38.82"	1200 mm / 47.24"	1382 mm / 54.40"	1558 mm / 61.34"
Depth	1450 mm / 57.09"	1450 mm / 57.09"	1450 mm / 57.09"	1595 mm / 68.80"
Weight	650 Kg - 1433 lbs	750 Kg / 1653.47 lbs	800 Kg / 1763.7 lbs	1020 Kg / 2248.7 lbs
Motor Power	4.2 Kw / 5.5 Kw	4.2 Kw / 5.5 Kw	5.5 Kw	5.5 Kw
Noise Level	71 db	71 db	71 db	71 lb
Maximum working width	396 mm / 15.59"	610 mm / 24.02"	792 mm / 31.20"	990 mm / 38.98"
Operator control circuit	24V	24V	24V	24V
Minimum slicing pitch bone-in	10 mm / 0.39"	10 mm / 0.39"	10 mm / 0.39"	12 mm / 0.47"
Minimum slicing pitch boneless	2.5 mm / 0.09"	3 mm / 0.12"	6.5 mm / 0.26"	10 mm / 0.39"
Air consumption	10 l/min	10 l/min	10 l/min	10 l/min



1. Ideal para múltiplas aplicações

O padrão de mercado em cortadores verticais com centenas de máquinas vendidas em todo o mundo, NSL é capaz de cortar produtos frescos a temperatura positiva ou congelados à superfície (até -4 -5 graus), tanto com ou sem osso, sem a produção de lascas.



2. Poupe tempo nos ajustes mecânicos

Sistema opcional de troca rápida de lâminas para mudar todo o conjunto de lâminas em poucos minutos, também facilitado pelo sistema automatizado de tensionamento de lâminas.



3. Extremamente adaptável para o máximo desempenho

Com uma vasta gama de opções de corte, os parâmetros de corte NSL podem ser ajustados para permitir a quantidade máxima de produto cortado.



4. Produtividade comprovada no terreno

A NSL provou que pode atingir uma capacidade de corte de até 2.000 kg/h, dependendo das condições do produto.



5. Soluções especiais disponíveis a pedido

A câmara de corte pode ser personalizada para satisfazer características específicas do produto, por exemplo, com espessuras de corte diferenciadas.



6. Opção de alimentação por empurrador

A NSL pode ser equipada com empurradores personalizados, concebidos para se adaptarem à forma e posição do carregamento, com o objetivo de alcançar um resultado final de fatias precisas agrupadas de acordo com a aparência do produto original.



7. Opção com osso (BI)

Versão BI disponível para produtos com osso, com um sistema de prensagem fracionada do produto e lâmina dedicada.



8. De fácil higienização sem utensílios

Obtém-se uma higienização perfeita sem qualquer utensílio necessário tanto para a lavagem como para a substituição das lâminas.



9. Construção sólida

O chassis da máquina é construído em aço inoxidável não radioativo testado e certificado para assegurar uma higiene superior e longevidade.



Visit our website

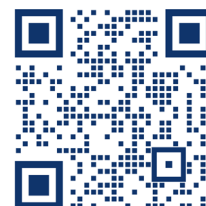

半自动纵向切片机

GRASSELLI^{SPA}
NSL 600



NSL

通过 Grasselli 多刀具切片系统, 纵向切片机可完美地切出肉片。

除了高生产效率和高产量外, 对最薄的厚度也具有极高的精度和质量: 构成鲜肉纵向切片机的市场标准。

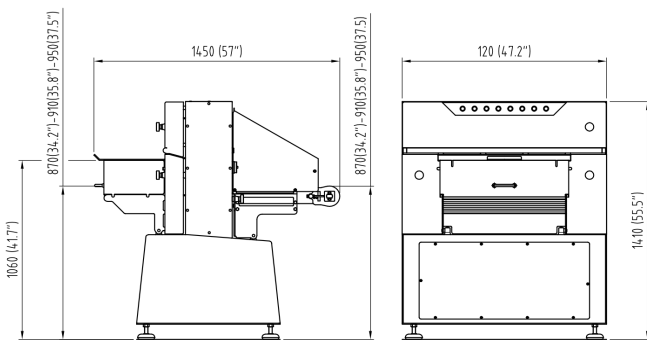

技术参数

	NSL 400	NSL 600	NSL 800	NSL 1000
Height	1410 mm / 55.50"	1410 mm / 55.50"	1410 mm / 55.50"	1410 mm / 55.50"
Width	986 mm / 38.82"	1200 mm / 47.24"	1382 mm / 54.40"	1558 mm / 61.34"
Depth	1450 mm / 57.09"	1450 mm / 57.09"	1450 mm / 57.09"	1595 mm / 68.80"
Weight	650 Kg - 1433 lbs	750 Kg / 1653.47 lbs	800 Kg / 1763.7 lbs	1020 Kg / 2248.7 lbs
Motor Power	4.2 Kw / 5.5 Kw	4.2 Kw / 5.5 Kw	5.5 Kw	5.5 Kw
Noise Level	71 db	71 db	71 db	71 lb
Maximum working width	396 mm / 15.59"	610 mm / 24.02"	792 mm / 31.20"	990 mm / 38.98"
Operator control circuit	24V	24V	24V	24V
Minimum slicing pitch bone-in	10 mm / 0.39"	10 mm / 0.39"	10 mm / 0.39"	12 mm / 0.47"
Minimum slicing pitch boneless	2.5 mm / 0.09"	3 mm / 0.12"	6.5 mm / 0.26"	10 mm / 0.39"
Air consumption	10 l/min	10 l/min	10 l/min	10 l/min



1. 多种应用的理想方案

构成纵向切片机的市场标准，已在全球销售数百台机器，NSL 切片机能够切割常温或表面冻结的新鲜产品（低至 -4/-5 度），无论带骨肉还是无骨肉，都不会产生碎骨渣。



2. 节省机械调整时间

可选快速更换刀具系统，由刀具自动张紧系统协助，在几分钟内完成整套刀具的更换。



3. 极易调整, 可实现极佳结果

NSL 切片机具有多种切割选项，能通过调整切割参数以实现最大的产品切割量。



4. 生产效率现场已验证

NSL 切片机已证明，根据产品的条件，切割速率可高达 2000 公斤/小时。



5. 可根据要求提供特殊方案

切割室可以定制，以满足产品的具体特性，例如不同的切割厚度。



6. 通过推杆选项

NSL 切片机可配备定制推杆，旨在适应形状和加载位置，以根据产品原外观分组获得精确切片的最终结果。



7. (BI) 剔骨选项

BI 版本可用于带骨肉，具有分离后的产品压制系统和专用刀片。



8. 轻松消毒, 无需工具

实现完美消毒，清洗和更换刀片操作均无需工具。



9. 坚固的结构

机器框架采用经过检验和认证的非放射性不锈钢制成，确保更高的卫生条件和更长的使用寿命。



Visit our website



